

Installation and User's Guide

MULTICAL[®] 601 & ULTRAFLOW[®]



Kamstrup

www.kamstrup.com

MID designations

Rated operation conditions/measuring ranges:

Calculator θ : 10°C...180°C $\Delta\theta$: 3K...170K

Temperature sensor pair θ : 10°C...150°C $\Delta\theta$: 3K...140K

Flow sensor θ : 15°C...130°C

Mechanical environment:

M1 (fixed installation with minimum vibration).

Electromagnetic environment:

E1 and E2 (Domestic, light industrial and industrial). Signal cables from the meter must be separated by at least 25cm distance to other installations.

Maintenance and repair:

The heat supplier is allowed to change communication module, battery, temperature sensor pair and flow sensor. Sensor pair and flow sensor are separately verified and can, therefore, be separated from the calculator. All repairs require a following re-verification on an accredited laboratory.

Climatic environment:

The installation shall be made in non-condensing environments and in closed location (indoor). The ambient temperature must be within 5...55°C.

MULTICAL® 601, type 67-B/C/D is suitable for temperature sensors type Pt500

MULTICAL® 601, type 67-A is suitable for temperature sensors type Pt100

Battery for replacement: Kamstrup type 66-00-200-100

MULTICAL® 601, type 67-A/B/C can be connected to flow sensor type ULTRAFLOW®, electronic pick-up unit or flow sensor with reed switch output.

MULTICAL® 601, type 67-D must be connected to a flow sensor with 24 V active pulse output.

Irrespective of flow sensor type, "pulse/litres" must be identical on flow sensor and calculator.

MULTICAL® 601 & ULTRAFLOW®

English

INSTALLATION



Kamstrup

Kamstrup A/S
Industrivej 28, Stilling, DK-8660 Skanderborg
Tel: +45 89 93 10 00 · Fax: +45 89 93 10 01
info@kamstrup.com · www.kamstrup.com

Contents

General information	4
Mounting of temperature sensors	4
<i>Pocket sensor pair</i>	4
<i>Short direct temperature sensor set</i>	5
Information codes “INFO”	5
Mounting of flow sensor	6
<i>Mounting of ULTRAFLOW® ≤ DN125</i>	7
<i>Mounting of ULTRAFLOW® 54 ≥ DN150</i>	7
<i>Mounting of ULTRAFLOW® 65 ≥ DN150</i>	7
<i>Installation examples</i>	8
Mounting of the calculator	9
<i>Compact mounting</i>	9
<i>Separately/wall mounting</i>	9
<i>Panel mounting</i>	9
Power supply for calculator/Pulse Transmitter	10
<i>Battery supply</i>	10
<i>Mains modules</i>	10
Operational check	11
Electrical connection for MULTICAL® and ULTRAFLOW®	11
<i>Connection example</i>	11
<i>Calculator with two flow sensors</i>	12
Plug-in modules	13
<i>Data + pulse inputs, type 67-00-10</i>	13
<i>M-Bus, type 67-00-20/27</i>	13
<i>Radio + pulse inputs, type 67-00-21/25/26</i>	14
<i>Prog. data logger + RTC + 4...20 mA inputs + pulse inputs (67-00-22)</i>	14
<i>Analog outputs</i>	15
<i>Lon Works</i>	15
<i>Wireless M-Bus, type 67-00-30</i>	15
<i>ZigBee + pulse inputs, type 67-00-60</i>	15
<i>Metasys N2 + pulse input, type 67-00-62</i>	15
<i>Top modules</i>	16
Electrical connection for MULTICAL®, ULTRAFLOW® and Pulse Transmitter	19

1. General information

⚠ Read this guide before installing the energy meter. If the meter is installed incorrectly, Kamstrup's guarantee obligations will no longer apply.

Please note that the following installation conditions must be obeyed:

- Pressure stage ULTRAFLOW®: PN16/PN25/PN40, see marking. Marking of flow part does not cover included accessories
- Pressure stage Kamstrup sensor set type DS: PN16
- Pressure stage Kamstrup stainless steel pockets: PN25/PN40 - depending on type

If the medium temperature exceeds 90°C we recommend to use flange meters and to mount MULTICAL® 601 on the wall.

2. Mounting of temperature sensors

Temperature sensors used to measure flow and return temperatures make up a matched pair of sensors and must never be separated.

Usually, MULTICAL® 601 is supplied with mounted temperature sensors. According to EN 1434 or OIML R75 the cable length must not be changed. Replacement of sensors, if required, must always be made in pairs.

One sensor is marked with a red sign, and must be installed in the flow pipe. The other sensor is marked with a blue sign, and must be installed in the return pipe (see paragraph 8 on page 11).

2.1 Pocket sensor pair

Preferably, sensor pockets must be mounted in tee-pieces or in 45° lateral Y-pieces. The tip of the sensor pocket must be placed pointing towards the flow direction and in the middle of the water flow.

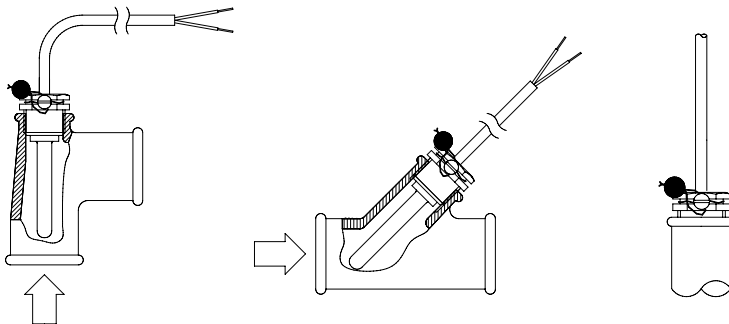

Temperature sensors should be inserted to the bottom of the pockets. If a quick response time is required, “non-hardening” heat conducting paste can be used.

Push the plastic sleeve on the sensor cable into the sensor pocket and secure the cable with the supplied M4 sealing screw. Fasten the screw with your fingers only. Seal the pockets using seal and sealing wire.

2.2 Short direct temperature sensor set

The short direct sensor can be mounted in special ball valves or in special angle tee-pipes, both with threads up to R1 and built-in M10 union for the short direct sensor.

For mounting in existing heating installations with standard angle tees Kamstrup A/S can also supply R $\frac{1}{2}$ and R $\frac{3}{4}$ brass nipples which fit the short direct sensors.

The short direct sensor can also be fitted directly into all ULTRAFLOW® variants from Kamstrup A/S with G $\frac{3}{4}$ and G1 thread on the meter case. Fasten the brass unions of the sensors lightly (approx. 4 Nm) by means of a 12 mm face wrench, and seal the sensors with seal and wire.

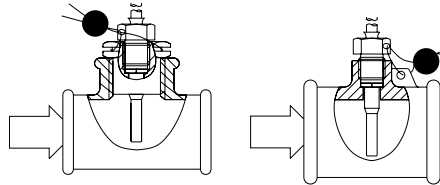

3. Information codes “INFO”

MULTICAL® 601 constantly monitors a series of important functions. If a serious error occurs in the measuring system or in the installation, an “INFO” appears in the display and an info code can be read by activating the upper front plate button until the measuring unit shows an “INFO” in the display. The info code is only visible while the error exists.

Info code	Description	Response time
0	No irregularities	-
1	Supply voltage has been cut off	-
8	Temperature sensor T1 outside measuring range	1...10 min.
4	Temperature sensor T2 outside measuring range	1...10 min.
32	Temperature sensor T3 outside measuring range	1...10 min.
64	Leak in the cold-water system	24 hours
256	Leak in the heating system	24 hours
512	Burst in the heating system	120 sec.
ULTRAFLOW® 54 info (if activated CCC=4XX)		
16	Flow sensor V1, Datacomm error, signal too low or wrong flow direction	After reset and 1 day (00:00)
1024	Flow sensor V2, Datacomm error, signal too low or wrong flow direction	After reset and 1 day (00:00)
2048	Flow sensor V1, Wrong meter factor	After reset and 1 day (00:00)
128	Flow sensor V2, Wrong meter factor	After reset and 1 day (00:00)
4096	Flow sensor V1, Signal too low (Air)	After reset and 1 day (00:00)
8192	Flow sensor V2, Signal too low (Air)	After reset and 1 day (00:00)
16384	Flow sensor V1, Wrong flow direction	After reset and 1 day (00:00)
32768	Flow sensor V2, Wrong flow direction	After reset and 1 day (00:00)

If several info codes appear at the same time the sum of the info codes is shown. E.g. if both temperature sensors are outside measuring range, info code 12 will appear.

4. Mounting of flow sensor

Before mounting the flow sensor, flush the system thoroughly and remove protection plugs/plastic membranes from the flow sensor. Correct flow sensor position (flow or return pipe) appears from the front label placed on the MULTICAL® 601. The flow direction is indicated by an arrow on the side of the flow sensor.

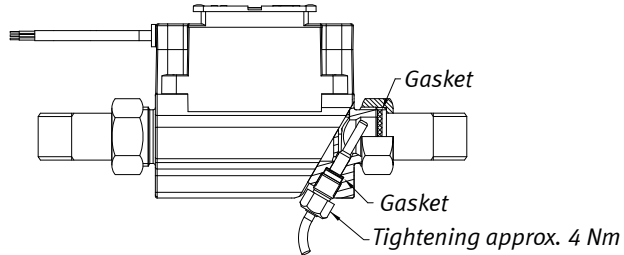

Glands and gaskets must be mounted as shown on the above drawing.

Straight inlet: ULTRAFLOW® requires neither straight inlet nor outlet to meet the Measuring Instruments Directive (MID) 2004/22/EEC, OIML R75:2002 and EN 1434:2007. Only in case of heavy flow disturbances before the meter will a straight inlet section be necessary. We recommend to follow the guidelines in CEN CR 13582.

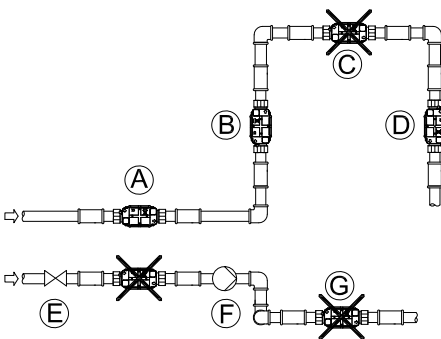

- A** Recommended position of flow meter
- B** Recommended position of flow meter
- C** Unacceptable position due to risk of air build-up
- D** Acceptable in closed systems. Unacceptable position in open systems due to risk of air build-up
- E** A flow meter ought not to be placed immediately after a valve, except from closing valves (ball check valve type), which must be completely open when not used for closing
- F** Never place a flow meter on the inlet side of a pump
- G** A flow meter ought not to be placed after a double bend, in two levels.

To prevent cavitation, the operating pressure at the ULTRAFLOW® must be min. 1.5 bar at q_p and min. 2.5 bar at q_s . This applies to temperatures up to approx. 80°C. ULTRAFLOW® must not be exposed to pressures below ambient pressure (vacuum).

4.1 Mounting of ULTRAFLOW® ≤ DN125

Electronics/plastic case must be placed on the side (when installed horizontally).

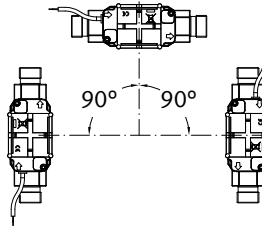

ULTRAFLOW® must be mounted vertically, horizontally or at any angle in between.

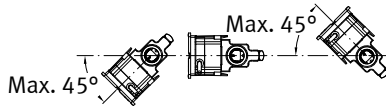

ULTRAFLOW® may be turned up to $\pm 45^\circ$ in relation to the pipe axis.

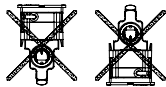

The ULTRAFLOW® housing must not be mounted facing upwards or downwards.

4.2 Mounting of ULTRAFLOW® 54 ≥ DN150

See Installation Guide No. 5512-887.

4.3 Mounting of ULTRAFLOW® 65 ≥ DN150

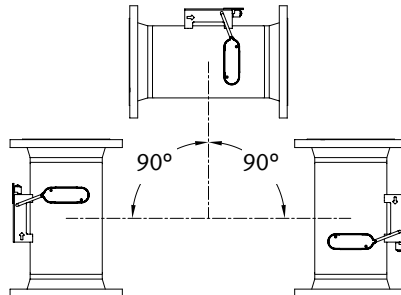

With ULTRAFLOW® \geq DN150 (150 m³/h) the box containing electronics must be placed on the top of the meter when it is installed horizontally.

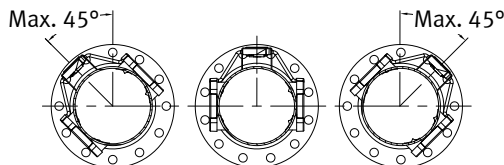

ULTRAFLOW® may be turned up to $\pm 45^\circ$ in relation to the pipe axis.

4.4 Installation examples

Threaded meter with MULTICAL®/Pulse Transmitter mounted on ULTRAFLOW®.

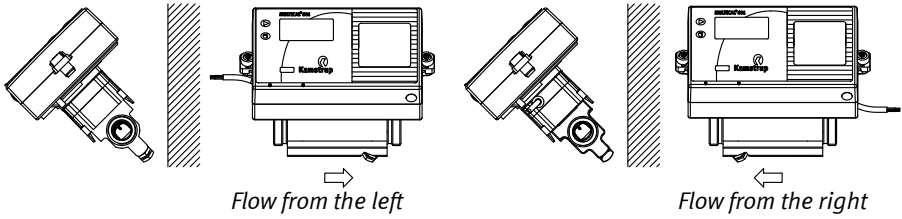

Flange meter with MULTICAL®/Pulse Transmitter mounted on ULTRAFLOW®.

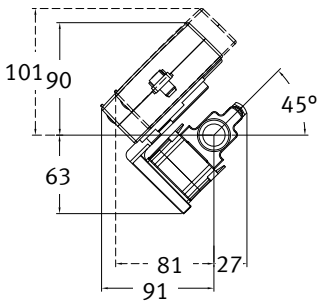
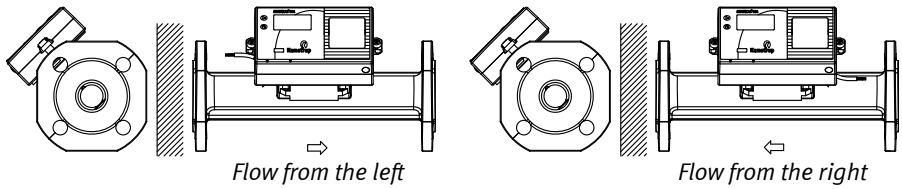

By means of the angle bracket MULTICAL® can be mounted in two positions. Angle bracket type 3026-252 must be ordered separately.

4.4.1 Humidity and condensation

When installed in humid environments ULTRAFLOW® must be turned 45° in relation to the pipe axis as shown below.

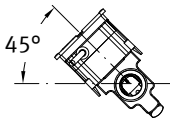

If condensation is likely, e.g. in cooling systems, an ULTRAFLOW® which is protected against condensation must be used.

5. Mounting of the calculator

The MULTICAL® 601 calculator can be mounted in three different ways:

5.1 Compact mounting

The calculator is fitted directly onto the flow sensor, by means of an angle bracket, if necessary. Once the calculator has been mounted it must be sealed with seal and wire. In connection with heavy condensing (e.g. cooling applications) we recommend to mount the calculator on the wall. *See also section "4.1 Mounting of ULTRAFLOW® ≤ DN125" on page 7.*

5.2 Separately/wall mounting

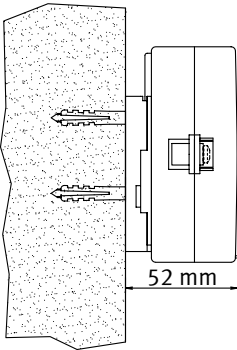

The wall bracket gives you the opportunity of mounting MULTICAL® 601 directly on an even wall. Use the bracket as a template to mark and drill two holes with a diameter of 6 mm in the wall.

5.3 Panel mounting

MULTICAL® 601 can be mounted directly into panels by means of Kamstrup's panel mounting kit, no. 66-99-104 (192 x 144 mm).

6. Power supply for calculator/Pulse Transmitter

MULTICAL® 601 can be power supplied by means of a built-in lithium battery, an internal 24 VAC mains module or an internal 230 VAC mains module.

The two wires from the battery or mains module are mounted in terminals 60 and 61 of the calculator.

⚠ The polarity has to be correct; connect the red wire to terminal no. 60 (+) and the black wire to terminal no. 61 (-).

6.1 Battery supply

MULTICAL® 601 is connected to a lithium battery, D-cell. The battery is marked with installation year, e.g. 2009, as well as production date.

Optimal battery life is obtained by keeping the battery temperature below 30°C, e.g. by wall mounting.

The voltage of a lithium battery is almost constant throughout the whole lifetime of the battery (approx. 3.65 V). Therefore, it is not possible to determine the remaining capacity by measuring the voltage.

The battery cannot and must not be charged and must not be short-circuited. Used batteries must be handed in for approved destruction, e.g. at Kamstrup's.

6.2 Mains modules

The modules are protection class II and are connected via a two-wire cable (without earth) through the cable bush of the calculator placed in the right side of the connecting base. Use a connecting cable with an outer diameter of 5–10 mm and ensure correct dismantling as well as correct mounting of the cable relief.

Max. permitted fuse: 6 A

National installation regulations must be obeyed.

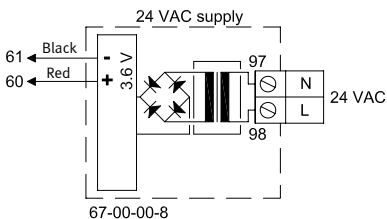

24 VAC

E.g. transformer 230/24 V, type 66-99-403 can be used.

NB! MULTICAL® 601 cannot be supplied from 24 VDC.

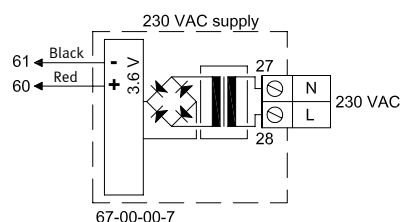

230 VAC

This module is used for direct mains connection.

NB! External supply must only be connected to the supply module.

7. Operational check

Carry out an operational check when the energy meter has been fully mounted. Open the thermo-regulators and cocks in order to establish a water flow through the heating system. Activate the upper push button on the MULTICAL® 601 and check that the display values for temperature and water flow are reliable.

8. Electrical connection for MULTICAL® and ULTRAFLOW®

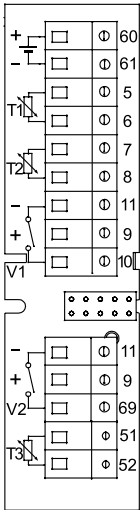

The polarity of the temperature sensors T1, T2 and T3 is unimportant. Use below colours at the flow sensors V1 and V2 when connecting the ULTRAFLOW® and electronic pick-up units.

Flow sensors with Reed switch output must be connected to terminals 11-10 and 11-69, respectively.

	V1	V2	
-	11	11	Blue
+	9	9	Red
SIG	10	69	Yellow

	Terminal No.	Standard measurement of heat and cooling	Heat measurement and leak surveillance	Energy measurement in open systems
T1	5-6	Sensor in flow pipe (red)	Sensor in flow pipe (red)	Sensor in flow pipe (red)
T2	7-8	Sensor in return pipe (blue)	Sensor in return pipe (blue)	Sensor in return pipe (blue)
V1	11-9-10	Flow sensor in flow or return pipe	Flow sensor in flow pipe	Flow sensor in flow pipe
V2	11-9-69	-	Flow sensor in return flow pipe	Flow sensor in return pipe
T3	51-52	-	Tank/heat exchanger temperature	Reference sensor (grey)

8.1 Connection example

Example of connection between ULTRAFLOW® and MULTICAL® (battery supply).

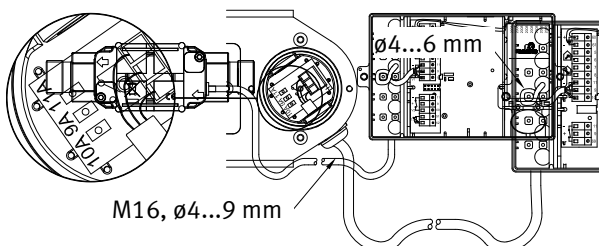

8.2 Calculator with two flow sensors

MULTICAL® 601 can be used in various applications with two flow sensors, e.g. leak surveillance or open systems. When two ULTRAFLOW® are direct connected to one MULTICAL® 601, a close electric coupling between the two pipes ought to be carried out as a main rule. If the two pipes are installed in a heat exchanger, close to the flow sensors, however, the heat exchanger will provide the necessary electric coupling.

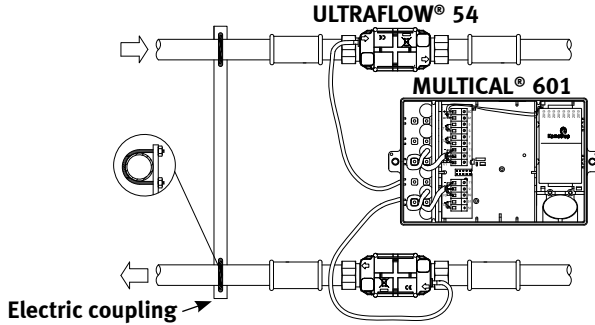

- Forward and return pipes are closely electrically coupled
- No welded joints occur

In installations where the electric coupling cannot be carried out, or where welding in the pipe system can occur, the cable from one ULTRAFLOW® must be routed through a Pulse Transmitter with galvanic separation before the cable enters MULTICAL® 601.

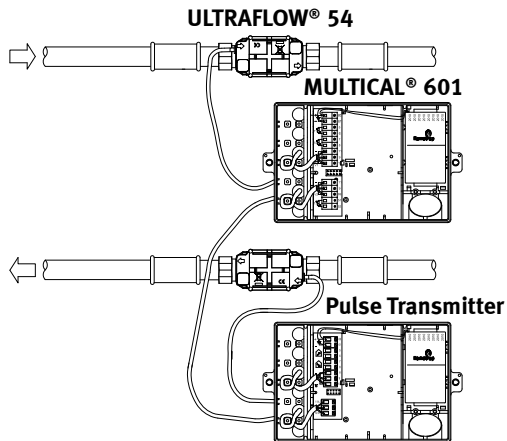

- Forward and return pipes are not necessarily closely coupled
- Electric welding *) can occur

*) Electric welding must always be carried out with the earth pole closest to the welding point. Damage to meters due to welding is **not** comprised by our factory guarantee.

9. Plug-in modules

MULTICAL® 601 can be extended with a number of extra functions in the form of plug-in modules. Below is a short description of the individual modules.

9.1 Data + pulse inputs, type 67-00-10

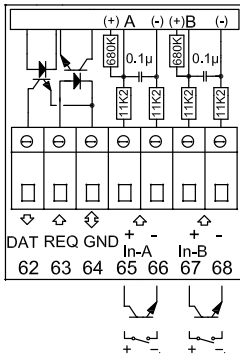

Data terminals are e.g. used for connecting a PC. The signal is passive and galvanically separated through optocouplers. Conversion into RS232 level requires connection of data cable 66-99-106 (D-Sub 9F) or 66-99-098 (USB) with the following connections:

62	Brown	(DAT)
63	White	(REQ)
64	Green	(GND)

NB! If data reading must be compatible with MULTICAL® 66-CDE, top module 67-06 must be used in MULTICAL® 601.

The pulse inputs can be used for connecting electricity and water meters. Please note the maximum pulse frequency and correct pulse coding (l/pulse and Wh/pulse) which are selected by means of the FF and GG configuration.

65 - 66	Input A
67 - 68	Input B

9.2 M-Bus, type 67-00-20/27

M-Bus can be mounted in star, ring or bus topology. Depending on the power supply of the M-Bus Master as well as the total cable resistance, up to 250 meters can be connected.

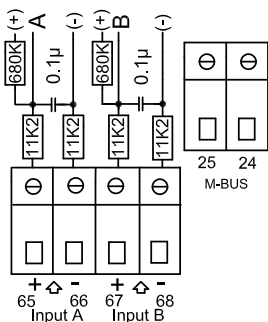

Cable resistance < 29 Ohm
Cable capacity < 180 nF

The M-Bus network is to be connected to terminals 24 and 25. The polarity is unimportant. M-Bus is supplied with pulse inputs.

9.3 Radio + pulse inputs, type 67-00-21/25/26

The radio module is used for wireless communication via a license-free radio frequency and is available for internal or external antenna.

For further information on radio please refer to *Technical Description for Radio (5512-013)*.

The pulse inputs in this module are identical with the ones described earlier.

NB! Type 67-00-21 includes radio and router functions.
The RadioRouter module (67-00-21) must be used with mains supply.

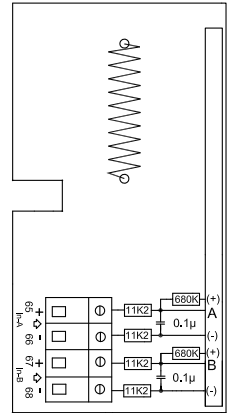

9.4 Prog. data logger + RTC + 4...20 mA inputs + pulse inputs (67-00-22)

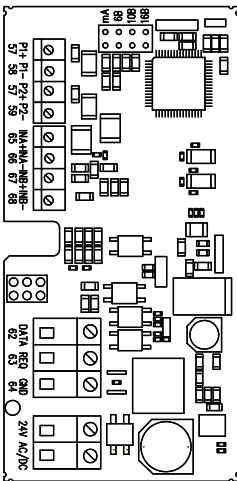

The module has connection possibility for two pressure transmitters on terminals 57, 58 and 59 and can be adjusted for current reading or pressure ranges of 6, 10 or 16 bar.

The module is prepared for remote reading, data from meter/module being transferred to the system software via the connected external GSM/GPRS modem on terminals 62, 63 and 64.

Furthermore, the module has two extra pulse inputs, VA and VB.

The module must always be powered by 24 VAC.

9.5 Analog outputs

Type 67-00-23, see *Installations manual 5512-369 (DK-GB-DE)*.

9.6 Lon Works

Type 67-00-24, see *Installations manual 5512-396 (DK) or 5512-403 (GB)*.

9.7 Wireless M-Bus, type 67-00-30

The radio module has been designed to form part of the hand-held Wireless M-Bus Reader systems of Kamstrup A/S using license-free radio frequency (868 MHz).

The module fulfils the C-mode specifications of prEN13757-4 and can, thus, also be part of other systems using wireless M-Bus C-mode communication.

The module comes with internal antenna and connection for external antenna as well as two pulse inputs, which are identical with the previously described pulse inputs.

9.8 ZigBee + pulse inputs, type 67-00-60

The ZigBee module is used for wireless communication and can form part of a remote reading system, enabling several units to communicate with each other.

The pulse inputs of this module are identical with the previously described pulse inputs.

The ZigBee module (67-00-60) requires mains supply.

9.9 Metasys N2 + pulse input, type 67-00-62

The N2 module is used for data communication between meters and N2 Masters in a Johnson Controls System.

The RS485 port is galvanically separated from the meter.

The pulse inputs of this module are identical with the previously described pulse inputs.

The N2 module (67-00-62) requires mains supply.

9.10 Top modules

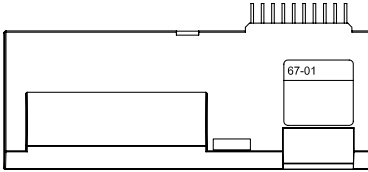
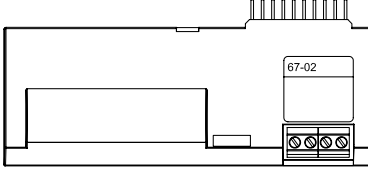
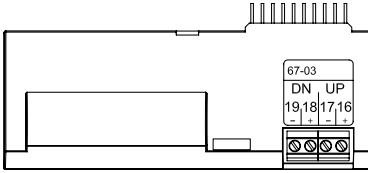
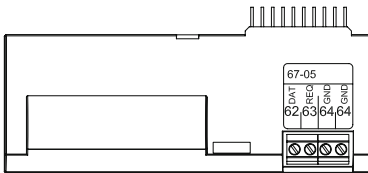
	<p>Type 67-01: RTC (Real Time Clock)</p> <p>The top module consists of real time clock and battery backup.</p> <p>When the MULTICAL® 601 calculator top is placed in the connecting bracket and is powered, current date and time is transferred from the top module to the calculator.</p> <p>The top module is recommended for applications in which correct date/time in data loggers as well as in time-controlled tariff is considered important. Real time clock and battery backup are standard features in all other top modules.</p> <p>Terminal screws are not used in this module.</p>
	<p>Type 67-02: RTC + Δenergy calculation and time data logger</p> <p>This top module calculates the difference between forward and return energy, whereby an expression of the tapped energy in open systems is obtained. The module also comprises a time data logger.</p> <p>Terminal screws are not used in this module</p>
	<p>Type 67-03: RTC + PQ-limiter + hourly data logger</p> <p>The module has two pulse outputs which can be used for UP/DOWN control of a low-speed three-point motor-operated valve via an external solid-state relay, type S75-90-006 and a 230/24 V trafo, type 66-99-403.</p> <p>The required power and flow limits are entered into MULTICAL® 601 via the PC-program METERTOOL. Also see instructions: 5512-498.</p> <p>The module also includes an hourly data logger.</p>
	<p>Type 67-05: RTC + data output + hourly data logger</p> <p>The module has a galvanically separated data port which functions together with the KMP-protocol. The data output can be used for e.g. connection of external communication units or other hardwired data communication which it is not expedient to carry out via the optical communication on the meter's front.</p> <p>62: DATA (Brown) – 63: REQ (White) – 64: GND (Green). Use data cable type 66-99-106 with 9-pole D-sub or type 66-99-098 with USB connector.</p> <p>The module also includes an hourly data logger. Only current and accumulated data can be read. Data loggers for time/days/months/years cannot be read through the data port of top module 67-05.</p>

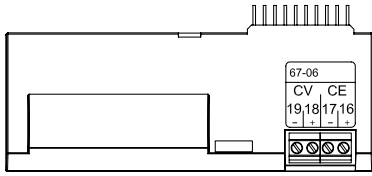

Type 67-06: RTC + 66-C compatibility + pulse outputs

The top module makes MULTICAL® 601 data compatible with MULTICAL® 66-C making it possible to use many of the previous base modules for MULTICAL® 66-C in MULTICAL® 601 too. Furthermore the top module has two pulse outputs for energy (CE) and volume (CV) respectively. The pulse resolution follows the display (determined in the CCC-code). E.g. CCC=119 (qp 1.5): 1 pulse/kWh and 1 pulse/0.01 m³. The pulse width is 32 ms. The pulse outputs are optoinsulated and stand 30 VDC and 10 mA.

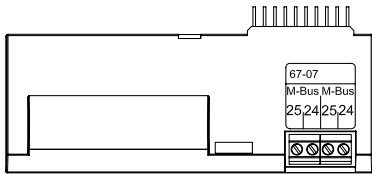

Type 67-07: RTC + M-Bus

M-Bus can be connected in star, ring and bus topology. Depending on the M-Bus Master and the cable length/cross section, up to 250 meters can be connected with primary addressing, and even more if secondary addressing is used.

Cable resistance in network: < 29 Ohm

Cable capacity in network: < 180 nF

The connection polarity of terminals 24-25 is unimportant.

Normally the primary address consists of the last digits of the customer number (000-250), but it can be changed via the PC program METERTOOL.

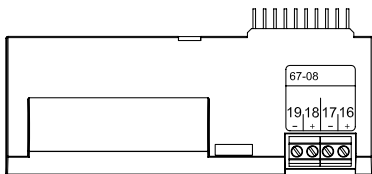

Type 67-08: RTC + hourly data logger + pulse outputs

This top module has two configurable pulse outputs, which are suitable for volume and energy pulses for heat meters, cooling meters and combined heat/cooling meters.

The pulse resolution follows the display (determined in the CCC-code). E.g. CCC=119 (qp 1.5):

1 pulse/kWh and 1 pulse/0.01 m³.

The pulse outputs are optoinsulated and stand 30 VDC and 10 mA.

Normally energy (CE) is connected to 16-17 and volume (CV) to 18-19, but other combinations can be selected via the PC program METERTOOL which is also used for selecting pulse widths 32 or 100 ms.

Furthermore, the module includes a hourly data logger.

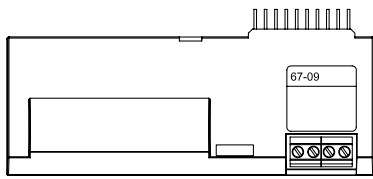

Type 67-09: RTC + Δ volume calculation and hourly data logger

This top module calculates the difference between forward and return volume, whereby an expression of the tapped energy in open systems is obtained. Differential volume $dV=V1-V2$.

The module also comprises a hourly data logger.

Terminal screws are not used in this module.

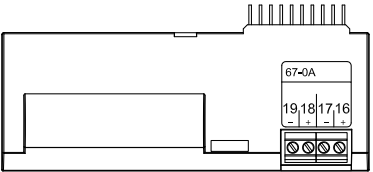

Type 67-0A: RTC + 2 pulse outputs for CE and CV + hourly data logger + scheduler

The top module has the same functions as the 67-08 top module and furthermore the module is able to simulate a cold water temperature according to a programmed scheduler, where the programmed temperature for T2, T3 or T4 can be programmed with up to 12 individual dates/temperatures per year.

This function is available for T3 and T4 of all MC601 models, but the scheduler function of T2 is restricted for the 67-E only.

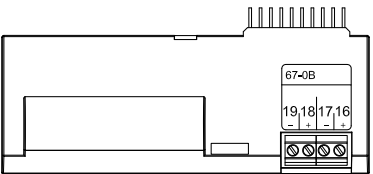

Type 67-0B: RTC + 2 pulse outputs for CE and CV + prog. data logger

The RTC and pulse output functions of this top module are identical with the functions described under top module 67-08.

The top module is prepared for use in a Kamstrup radio network together with the Radio Router base module 6700210003xx, read data being transferred to the system software via network unit RF Concentrator.

10. Electrical connection for MULTICAL®, ULTRAFLOW® and Pulse Transmitter

Connecting MULTICAL® and ULTRAFLOW®

ULTRAFLOW®	→	MULTICAL®
Blue (GND)/11A	→	11
Red (supply)/9A	→	9
Yellow (signal)/10A	→	10

ULTRAFLOW®	→	Pulse Transmitter		→	MULTICAL®
		In	Out		
Blue (GND)/11A	→	11	11A	→	11
Red (supply)/9A	→	9	9A	→	9
Yellow (signal)/10A	→	10	10A	→	10

Connecting via Pulse Transmitter

3,65 VDC supply ¹⁾	→	Pulse Transmitter
Red (+)	→	60
Black (-)	→	61

1) from battery or supply module.

If long signal cables are used, please consider the installation carefully. There must be **at least 25 cm** between the signal cable and all other cables due to EMC.

Electric connection

Connection to the Pulse Transmitter

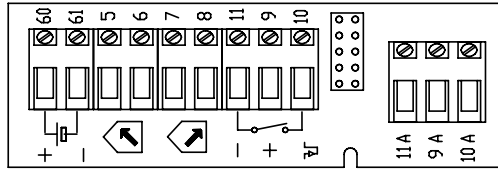

Block diagram

The Pulse Transmitter outlet

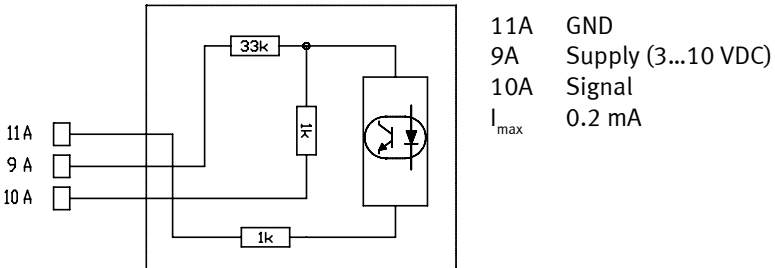

If ULTRAFLOW® 54 is used as pulse generator for other equipment, it must be connected through a Pulse Transmitter.

Consumed energy in kWh, MWh or GJ

E 1
0045.321
MWh

DATE LOG
20060601

Latest yearly target date

LOG
0031.07
MWh

Energy consumption count on latest yearly target date, followed by previous yearly target date.
Followed by monthly target date

VOL
0032456
m³

DATE LOG
20060601

Latest yearly target date

LOG VOL
0023195
m³

District heating water volume count on latest yearly target date, followed by previous yearly target date.
Followed by monthly target date

Number of operating hours

0008760
h

Current flow pipe temperature
(*) Press to see yearly and monthly average values

t 1
76.89
°C

Current return pipe temperature
(*) Press to see yearly and monthly average values

t 2
34.21
°C

Current temperature difference

t 1-2
42.68
K

VOL
316
l/h

Current water flow
(*) Press to see the peak value of the current year and historic yearly and monthly values

146
kW

Current heat power
(*) Press to see the peak value of the current year and historic yearly and monthly values.
Followed by the accumulated water consumption on inputs A and B and tariff registers R2 and R1

INFO
256

Current information code
(connect the utility if the figure differs from "0")

INFO N°
0

Indication of the number of current and corrected error conditions

INFO LOG
20060104

Data logger indicates the date ...

INFO LOG
512

... and the INFO code of the latest 36 changes



The first max. 8 digits of the customer number

N° 123



N° 45678912

The latest 8 digits of the customer number. This example displays customer number 12345678912

DATE 2006.1.129

Current date

TIME 16.25.43

Current time

DATE LOG 06.01

The target date appears in the order of month and day. In this example 1 June

N° 6044052

The counter's serial number

N° 441919

The counter's program number. In this example: installed in return flow, MWh and 100 imp/l. Followed by the calculator's configuration number and software edition.

DATE LOG 06.01.129
TIME BAUD 1200
DATE FOR 06.01.129
VOL 1.000
L 1.000
E 1.000
T 1.000
C 1.000
G 1.000
M 1.000
W 1.000
h 1.000
m 1.000
s 1.000
bar 1.000
°C 1.000
°F 1.000
imp/h 1.000
imp/m³ 1.000
imp/l 1.000

Display segment test Followed by the types of top and base modules

DDD = 213/413
(*) DDD = 212/412

Also see interactive user guides at www.kamstrup.com

MULTICAL® 601

Energy metering

MULTICAL® 601 functions in the following way:

The flow sensor registers how many m³ (cubic metres) of district heating water are circulating through the heating system.

The temperature sensors, placed in flow and return flow pipes, register cooling, i.e. the difference between the input and output temperatures.

MULTICAL® 601 calculates the consumed amount of energy based on the district heating water volume and cooling.

Readings in the display

When the upper front key is activated, a new reading appears.

The lower front key displays historical readings and average values.

4 minutes after the front key has been activated reading of consumed energy will automatically appear.



www.kamstrup.com