

## Up to PL e of EN ISO 13849-1 PNOZ s5

مبتکران صنعت برنا  
جهت سفارش با شماره زیر تماس بگیرید  
0990 4040 832 msborna.com



Safety relay for monitoring E-STOP pushbuttons, safety gates and light beam devices

### Approvals

PNOZ s5	
	◆
	◆
	◆

### Unit features

- ▶ Positive-guided relay outputs:
  - 2 safety contacts (N/O), instantaneous
  - 2 safety contacts (N/O), delay-on de-energisation
- ▶ 1 semiconductor output
- ▶ Connection options for:
  - E-STOP pushbutton
  - Safety gate limit switch
  - Reset button
  - Light barriers
  - PSEN
- ▶ A connector can be used to connect 1 PNOZsigma contact expander module
- ▶ Delay-on de-energisation selectable
- ▶ Operating modes and delay times can be selected via rotary switches
- ▶ LED indicator for:
  - Supply voltage
  - Input status, channel 1
  - Input status, channel 2
  - Switch status channel 1/2
  - Reset circuit
  - Error
- ▶ Plug-in connection terminals (either spring-loaded terminal or screw terminal)

▶ See order reference for unit types

### Unit description

The safety relay meets the requirements of EN 60947-5-1, EN 60204-1 and VDE 0113-1 and may be used in applications with

- ▶ E-STOP pushbuttons
- ▶ Safety gates
- ▶ Light beam devices

### Safety features

The relay meets the following safety requirements:

- ▶ The circuit is redundant with built-in self-monitoring.
- ▶ The safety function remains effective in the case of a component failure.
- ▶ The correct opening and closing of the safety function relays is tested automatically in each on-off cycle.
- ▶ The unit has an electronic fuse.

### Block diagram

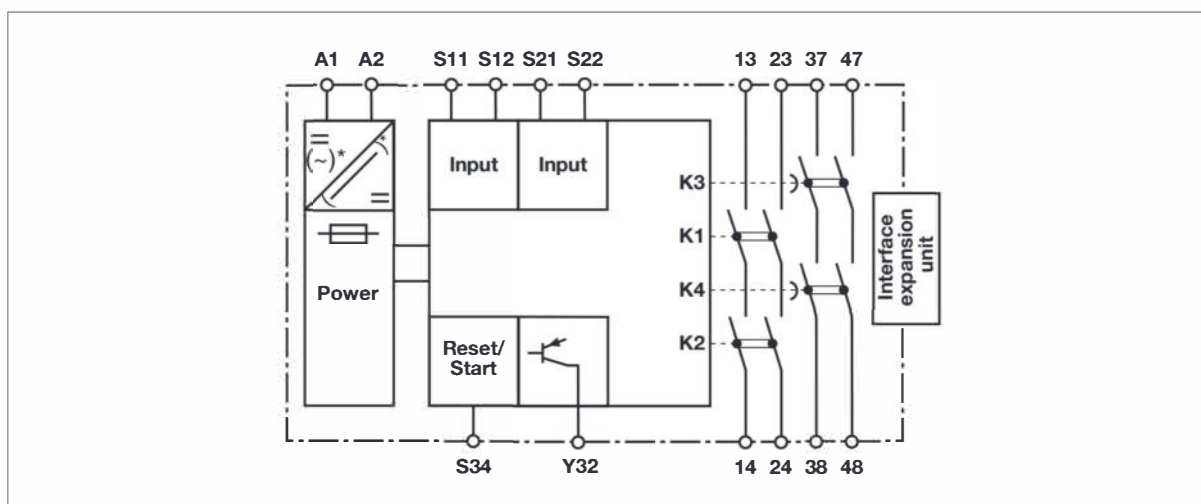

\* only when  $U_B = 48 - 240 \text{ VAC/DC}$

## Up to PL e of EN ISO 13849-1 PNOZ s5

مبتکران صنعت برنا  
جهت سفارش با شماره زیر تماس بگیرید  
0990 4040 832 msborna.com

### Function description

- ▶ Single-channel operation: no redundancy in the input circuit, earth faults in the reset and input circuit are detected.
- ▶ Dual-channel operation without detection of shorts across contacts: redundant input circuit, detects
  - earth faults in the reset and input circuit,
  - short circuits in the input circuit and, with a monitored reset, in the reset circuit too.
- ▶ Dual-channel operation with detection of shorts across contacts: redundant input circuit, detects
  - earth faults in the reset and input circuit,
  - short circuits in the input circuit and, with a monitored reset, in the reset circuit too,
  - shorts between contacts in the input circuit.
- ▶ Automatic start: Unit is active once the input circuit has been closed.
- ▶ Manual reset: Unit is active once the input circuit is closed and then the reset circuit is closed.
- ▶ Monitored reset with falling edge: Unit is active once
  - the input circuit is closed and then the reset circuit is closed and opened again.
  - the reset circuit is closed and then opened again once the input circuit is closed.
- ▶ Monitored reset with rising edge: Unit is active once the input circuit is closed and once the reset circuit is closed after the waiting period has elapsed (see technical details).
- ▶ Reset with start-up test: The unit checks whether safety gates that are closed are opened and then closed again when supply voltage is applied.
- ▶ Ability to increase the number of contacts available on the
  - instantaneous safety contacts by using connectors to link to a PNOZsigma contact expansion module
  - delayed/instantaneous safety contacts by connecting contact expansion modules or external contactors

## Up to PL e of EN ISO 13849-1 PNOZ s5

مبتکران صنعت برنا  
جهت سفارش با شماره زیر تماس بگیرید  
0990 4040 832 msborna.com

### Timing diagram

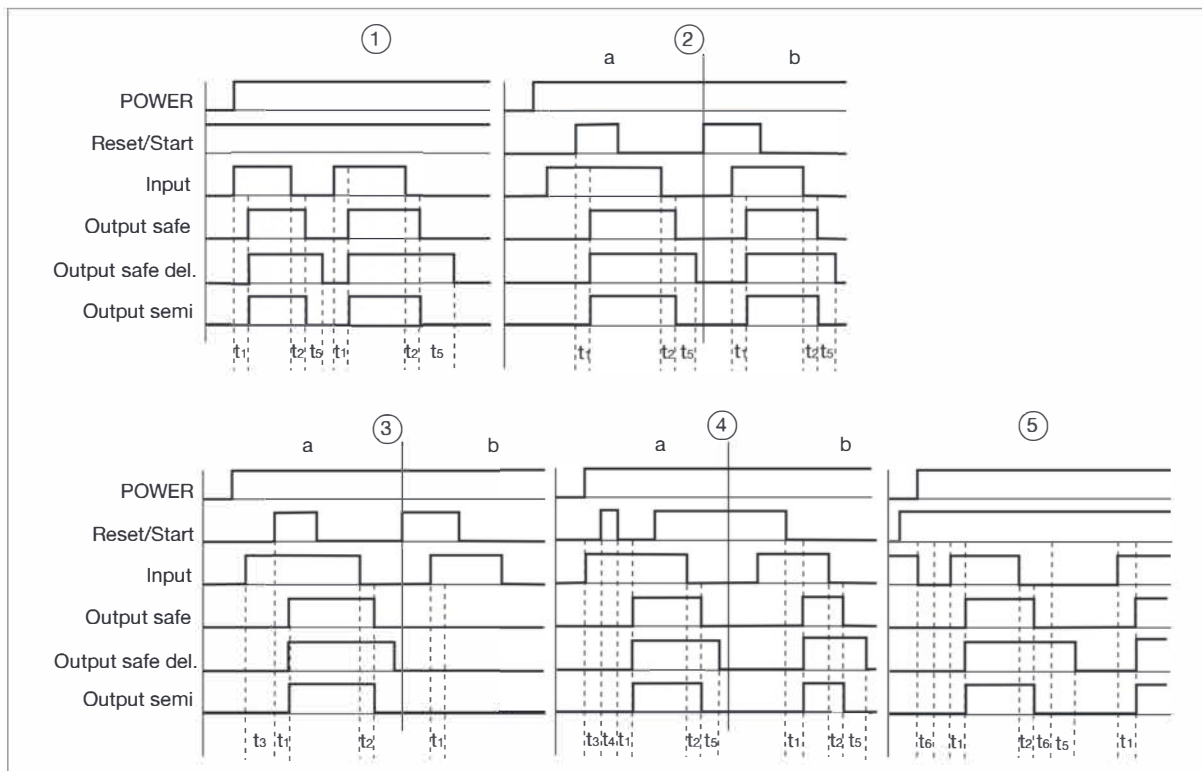

### Key

- ▶ Power: Supply voltage
- ▶ Reset/Start: Reset circuit S12-S34
- ▶ Input: Input circuits S11-S12, S21-S22
- ▶ Output safe: Safety contacts 13-14, 23-24
- ▶ Out semi: Semiconductor output Y32
- ▶ ①: Automatic reset
- ▶ ②: Manual reset
- ▶ ③: Monitored reset with rising edge
- ▶ ④: Monitored reset with falling edge
- ▶ ⑤: Reset with start-up test
- ▶ a: Input circuit closes before reset circuit
- ▶ b: Reset circuit closes before input circuit
- ▶ t<sub>1</sub>: Switch-on delay
- ▶ t<sub>2</sub>: Delay-on de-energisation
- ▶ t<sub>3</sub>: Waiting period
- ▶ t<sub>4</sub>: Waiting period reset circuit was closed
- ▶ t<sub>5</sub>: Delay time
- ▶ t<sub>6</sub>: Minimum time safety gates open

### Wiring

Please note:

- ▶ Information given in the “Technical details” must be followed.
- ▶ Outputs 13-14, 23-24 are instantaneous safety contacts, outputs 37-38, 47-48 are delay-on de-energisation safety contacts.
- ▶ To prevent contact welding, a fuse should be connected before the output contacts (see technical details).
- ▶ Calculation of the max. cable runs  $I_{max}$  in the input circuit:

$$I_{max} = \frac{R_{lmax}}{R_l / km}$$

$R_{lmax}$  = max. overall cable resistance (see technical details)

$R_l / km$  = cable resistance/km

- ▶ Use copper wire that can withstand 60/75 °C.
- ▶ Sufficient fuse protection must be provided on all output contacts with capacitive and inductive loads.
- ▶ With  $U_B$  48 – 240 VAC/DC: Connect S21 to the protective earth system

## Up to PL e of EN ISO 13849-1 PNOZ s5

مبتکران صنعت برنا  
جهت سفارش با شماره زیر تماس بگیرید  
0990 4040 832 msborna.com

### Preparing for operation

#### ► Supply voltage

Supply voltage	AC	DC

#### ► Input circuit

Input circuit	Single-channel	Dual-channel
E-STOP <b>without</b> detection of shorts across contacts		
E-STOP <b>with</b> detection of shorts across contacts		
Safety gate <b>without</b> detection of shorts across contacts		
Safety gate <b>with</b> detection of shorts across contacts		
Light beam device or safety switch <b>with</b> detection of shorts across contacts via ESPE (only when $U_B = 24 \text{ VDC}$ )		

## Up to PL e of EN ISO 13849-1 PNOZ s5

مبتکران صنعت برنا  
جهت سفارش با شماره زیر تماس بگیرید  
0990 4040 832 msborna.com

### Reset circuit/feedback loop

Reset circuit/feedback loop	Reset circuit	Feedback circuit
Automatic reset		
Manual/monitored reset		

### Semiconductor output

$U_B$ 24 VDC	$U_B$ 48 – 240 VAC/DC
*Connect together the 0V connections on all the external power supplies	

### Key

S1/S2	E-STOP/safety gate switch
S3	Reset button
	Switch operated
	Gate open
	Gate closed

## Up to PL e of EN ISO 13849-1 PNOZ s5

مبتکران صنعت برنا  
جهت سفارش با شماره زیر تماس بگیرید  
0990 4040 832 msborna.com

### Terminal configuration

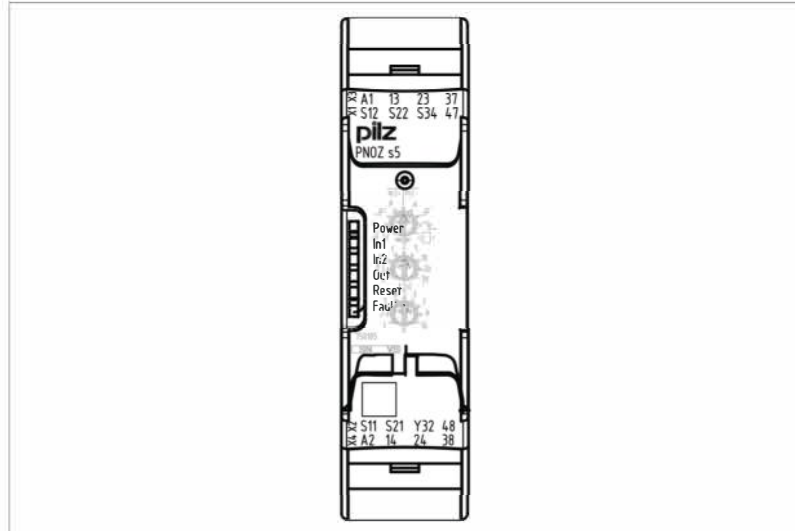

### Installation

#### Install base unit without contact expander module:

- ▶ Ensure that the plug terminator is inserted at the side of the unit.

#### Connect base unit and PNOZsigma contact expander module:

- ▶ Remove the plug terminator at the side of the base unit and at the contact expander module.
- ▶ Connect the base unit and the contact expander module to the supplied connector before mounting the units to the DIN rail.

#### Installation in control cabinet

- ▶ The safety relay should be installed in a control cabinet with a protection type of at least IP54.
- ▶ Use the notch on the rear of the unit to attach it to a DIN rail (35 mm).
- ▶ When installed vertically: Secure the unit by using a fixing element (e.g. retaining bracket or end angle).
- ▶ Push the unit upwards or downwards before lifting it from the DIN rail.

### Dimensions

\*with spring-loaded terminals

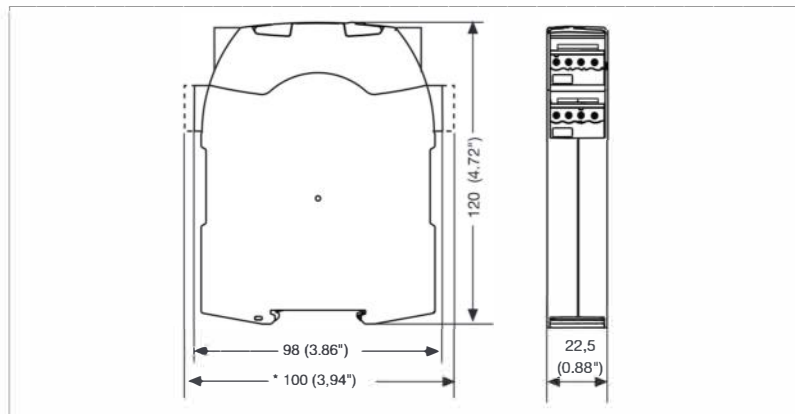

## Up to PL e of EN ISO 13849-1 PNOZ s5

مبتکران صنعت برنا  
جهت سفارش با شماره زیر تماس بگیرید  
0990 4040 832 msborna.com

### Notice

This data sheet is only intended for use during configuration. For installation and operation, please refer to the operating instructions supplied with the unit.

### Service life graph

The service life graphs indicate the number of cycles from which failures due to wear must be expected. The wear is mainly caused by the electrical load; the mechanical load is negligible.

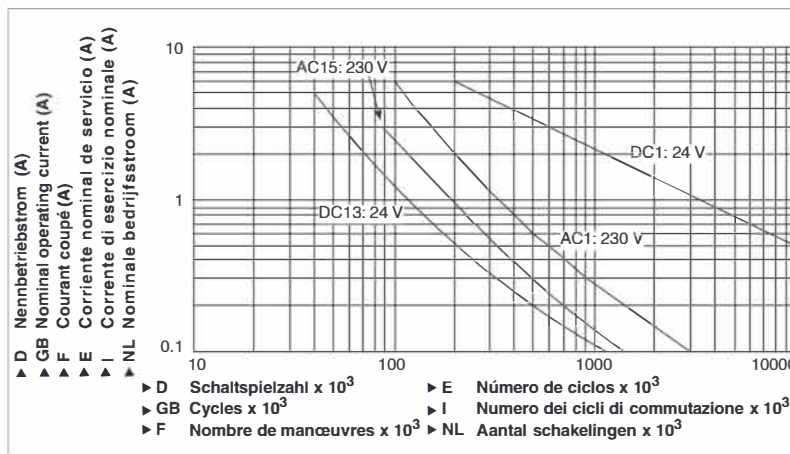

### Example

- ▶ Inductive load: 0.2 A
  - ▶ Utilisation category: AC15
  - ▶ Contact service life: 700 000 cycles
- Provided the application requires fewer than 700 000 cycles, the PFH value

(see technical details) can be used in the calculation. To increase the service life, sufficient spark suppression must be provided on all output contacts. With capacitive loads, any power surges that occur

must be noted. With contactors, use freewheel diodes for spark suppression. We recommend you use semiconductor outputs to switch 24 VDC loads.

### Technical details

#### Electrical data

Supply voltage	
Supply voltage U <sub>B</sub> DC	<b>24 V</b>
Supply voltage U <sub>B</sub> AC/DC	<b>48 - 240 V</b>
Voltage tolerance	<b>-15 %/+10 %</b>
Power consumption at U <sub>B</sub> AC	<b>8.0 VA</b> No. 751135, 751135
Power consumption at U <sub>B</sub> DC	<b>4.0 W</b>
Frequency range AC	<b>50 - 60 Hz</b>
Residual ripple DC	<b>20 %, 160 %</b>
Voltage and current at	
Input circuit DC: <b>24.0 V</b>	<b>40.0 mA</b>
Reset circuit DC: <b>24.0 V</b>	<b>40.0 mA</b>
Feedback loop DC: <b>24.0 V</b>	<b>40.0 mA</b>
Number of output contacts	
Safety contacts (S) instantaneous:	<b>2</b>
Safety contacts (N/O), delayed:	<b>2</b>

## Up to PL e of EN ISO 13849-1 PNOZ s5

مبتکران صنعت برنا  
جهت سفارش با شماره زیر تماس بگیرید  
0990 4040 832 msborna.com

### Electrical data

Utilisation category in accordance with **EN 60947-4-1**

Safety contacts: AC1 at **240 V**

$I_{min}$ : **0.01 A** ,  $I_{max}$ : **6.0 A**

$P_{max}$ : **1500 VA**

Safety contacts: DC1 at **24 V**

$I_{min}$ : **0.01 A** ,  $I_{max}$ : **6.0 A**

$P_{max}$ : **150 W**

Safety contacts, delayed: AC1 at **240 V**

$I_{min}$ : **0.01 A** ,  $I_{max}$ : **6.0 A**

$P_{max}$ : **1500 VA**

Safety contacts, delayed: DC1 at **24 V**

$I_{min}$ : **0.01 A** ,  $I_{max}$ : **6.0 A**

$P_{max}$ : **150 W**

Utilisation category in accordance with **EN 60947-5-1**

Safety contacts: AC15 at **230 V**

$I_{max}$ : **3.0 A**

Safety contacts: DC13 at **24 V** (6 cycles/min)

$I_{max}$ : **4.0 A**

Safety contacts, delayed: AC15 at **230 V**

$I_{max}$ : **3.0 A**

Safety contacts, delayed: DC13 at **24 V** (6 cycles/min)

$I_{max}$ : **4.0 A**

Contact material

**AgCuNi + 0.2 µm Au**

External contact fuse protection ( $I_K = 1$  kA) to **EN 60947-5-1**

Blow-out fuse, quick

Safety contacts:

**6 A**

Safety contacts, delayed:

**6 A**

Blow-out fuse, slow

Safety contacts:

**4 A**

Safety contacts, delayed:

**4 A**

Circuit breaker 24 VAC/DC, characteristic B/C

Safety contacts:

**4 A**

Safety contacts, delayed:

**4 A**

Semiconductor outputs (short circuit proof)

**24.0 V DC, 20 mA**

Max. overall cable resistance  $R_{lmax}$   
input circuits, reset circuits

single-channel at  $U_B$  DC

**30 Ohm**

single-channel at  $U_B$  AC

**30 Ohm** No. 750135, 751135

dual-channel without detect. of shorts across contacts at  $U_B$  DC

**30 Ohm**

dual-channel without detect. of shorts across contacts at  $U_B$  AC

**30 Ohm** No. 750135, 751135

dual-channel with detect. of shorts across contacts at  $U_B$  DC

**30 Ohm**

dual-channel with detect. of shorts across contacts at  $U_B$  AC

**30 Ohm** No. 750135, 751135

Min. input resistance in the starting torque

**110 Ohm**

### Safety-related characteristic data

PL in accordance with **EN ISO 13849-1: 2006**

Safety contacts, instantaneous

**PL e (Cat. 4)**

Safety contacts, delayed

**PL e (Cat. 4)**

Category in accordance with **EN 954-1**

Safety contacts, instantaneous

**Cat. 4**

Safety contacts, delayed

**Cat. 4**

SIL CL in accordance with **EN IEC 62061**

Safety contacts, instantaneous

**SIL CL 3**

Safety contacts, delayed

**SIL CL 3**

PFH in accordance with **EN IEC 62061**

Safety contacts, instantaneous

**2.31E-09**

Safety contacts, delayed

**2.34E-09**

SIL in accordance with **IEC 61511**

Safety contacts, instantaneous

**SIL 3**

Safety contacts, delayed

**SIL 3**

PFD in accordance with **IEC 61511**

Safety contacts, instantaneous

**2.03E-06**

Safety contacts, delayed

**2.75E-05**

$t_M$  in years

**20**

## Up to PL e of EN ISO 13849-1 PNOZ s5

مبتکران صنعت برنا  
جهت سفارش با شماره زیر تماس بگیرید  
0990 4040 832 msborna.com

Times	
Switch-on delay	
with automatic reset typ.	180 ms
with automatic reset max.	400 ms
with automatic reset after power on typ.	1,430 ms
with automatic reset after power on max.	2,000 ms
with manual reset typ.	45 ms
with manual reset max.	85 ms
on monitored reset with rising edge typ.	45 ms
on monitored reset with rising edge max.	130 ms
on monitored reset with falling edge typ.	60 ms
on monitored reset with falling edge max.	150 ms
Delay-on de-energisation	
with E-STOP typ.	15 ms
with E-STOP max.	20 ms
with power failure typ.	75 ms
with power failure max.	110 ms
Recovery time at max. switching frequency 1/s	
after E-STOP	150 ms +tv
after power failure	200 ms
Delay time $t_V$ : selectable	0,00 s; 0,10 s; 0,20 s; 0,30 s; 0,40 s; 0,50 s; 0,60 s; 0,70 s; 0,80 s; 1,00 s; 1,50 s; 2,00 s; 2,50 s; 3,00 s; 3,50 s; 4,00 s; 5,00 s; 6,00 s; 7,00 s; 8,00 s; 10,00 s; 12,00 s; 14,00 s; 15,00 s; 16,00 s; 20,00 s; 25,00 s; 30,00 s; 35,00 s; 40,00 s; 50,00 s; 60,00 s; 70,00 s; 80,00 s; 90,00 s; 100,00 s; 120,00 s; 140,00 s; 150,00 s; 160,00 s; 180,00 s; 200,00 s; 210,00 s; 240,00 s; 300,00 s
Repetition accuracy	-1 %/+1 %, -20 ms/+20 ms
Repetition accuracy in the case of a fault	-15 %/+15 %, -20 ms/+20 ms
Time accuracy	-1 %/+1 %, -20 ms/+20 ms
Waiting period with a monitored reset	
with rising edge	150 ms
with falling edge	240 ms
Min. start pulse duration with a monitored reset	
with rising edge	30 ms
with falling edge	70 ms
Simultaneity, channel 1 and 2	∞
Supply interruption before de-energisation	20 ms
Environmental data	
EMC	EN 60947-5-1, EN 61000-6-2, EN 61000-6-4
Vibration to EN 60068-2-6	
Frequency	10 - 55 Hz
Amplitude	0.35 mm
Climatic suitability	EN 60068-2-78
Airgap creepage in accordance with EN 60947-1	
Pollution degree	2
Overvoltage category	III
Rated insulation voltage	250 V
Rated impulse withstand voltage	4.00 kV
Ambient temperature	-10 - 55 °C
Storage temperature	-40 - 85 °C
Protection type	
Mounting (e.g. cabinet)	IP54
Housing	IP40
Terminals	IP20
Mechanical data	
Housing material	
Housing	PC
Front	PC

## Up to PL e of EN ISO 13849-1 PNOZ s5

مبتکران صنعت برنا  
جهت سفارش با شماره زیر تماس بگیرید  
0990 4040 832 msborna.com

### Mechanical data

Cross section of external conductors with screw terminals	
1 core flexible	<b>0.25 - 2.50 mm<sup>2</sup> , 24 - 12 AWG</b> No. 750105, 750135
2 core, same cross section, flexible:	
with crimp connectors, without insulating sleeve	<b>0.25 - 1.00 mm<sup>2</sup> , 24 - 16 AWG</b> No. 750105, 750135
without crimp connectors or with TWIN crimp connectors	<b>0.20 - 1.50 mm<sup>2</sup> , 24 - 16 AWG</b> No. 750105, 750135
Torque setting with screw terminals	<b>0.50 Nm</b> No. 750105, 750135
Cross section of external conductors with spring-loaded terminals: Flexible with/without crimp connectors	<b>0.20 - 2.50 mm<sup>2</sup> , 24 - 12 AWG</b> No. 751105, 751135, 751185
Spring-loaded terminals: Terminal points per connection	<b>2</b> No. 751105, 751135, 751185
Stripping length	<b>9 mm</b> No. 751105, 751135, 751185
Dimensions	
Height	<b>102.0 mm</b> No. 751105, 751135, 751185 <b>96.0 mm</b> No. 750105, 750135
Width	<b>22.5 mm</b>
Depth	<b>120.0 mm</b>
Weight	<b>235 g</b> No. 750105, 751105, 751185 <b>280 g</b> No. 750135, 751135

No. stands for order number.

It is essential to consider the relay's service life graphs. The relay outputs' safety-related characteristic data is only valid if the values in the service life graphs are met.

The PFH value depends on the switching frequency and the load on the relay output.

If the service life graphs are not accessible, the stated PFH value can be

used irrespective of the switching frequency and the load, as the PFH value already considers the relay's B10d value as well as the failure rates of the other components.

All the units used within a safety function must be considered when calculating the safety characteristic data.

The standards current on **2006-04** apply.

### Conventional thermal current

I <sub>th</sub> (A) at U <sub>B</sub> DC	
1 contact	<b>6.00 A</b>
2 contacts	<b>6.00 A</b>
3 contacts	<b>6.00 A</b>
4 contacts	<b>6.00 A</b>

### Order reference

Type	Features	Terminals	Order no.
PNOZ s5		24 VDC	With screw terminals 750 105
PNOZ s5 C		24 VDC	With spring-loaded terminals 751 105
PNOZ s5 C (coated version)		24 VDC	With spring-loaded terminals 751 185
PNOZ s5	48 - 240 VAC	48 - 240 VDC	With screw terminals 750 135
PNOZ s5 C	48 - 240 VAC	48 - 240 VDC	With spring-loaded terminals 751 135