

## up to PL e of EN ISO 13849-1 PNOZ s9

مبتکران صنعت برنا  
جهت سفارش با شماره زیر تماس بگیرید  
0990 4040 832 msborna.com



Contact expander module for increasing the number of available contacts, Pulse-on timer relay for step-by-step control of movement sequences, Delay-on energisation timer for unlocking an interlock with delay, Shutdown of application with delay-on de-energisation, controlled stop

### Approvals

|  | PNOZ s9 |
|--|---------|
|  | ◆       |
|  | ◆       |
|  | ◆       |

### Unit features

- ▶ Positive-guided relay outputs, either instantaneous, delay-on de-energisation (also retriggerable), pulsing or delay-on energisation:
  - 3 safety contacts
  - 1 auxiliary contact
- ▶ Safe separation of safety contacts 17-18, 27-28, 37-38 from all other circuits
- ▶ Switch-on time, pulse time or delay-on de-energisation selectable
- ▶ LED for:
  - Supply voltage
  - Input status, channel 1
  - Input status, channel 2
  - Switch status channel 1/2
  - Reset circuit
  - Errors
- ▶ Plug-in connection terminals (either spring-loaded terminals or screw terminals)

### Unit description

The unit meets the requirements of EN 60947-5-1, EN 60204-1 and VDE0113-1. In conjunction with a base unit the unit is used as a

- ▶ Contact expansion module to increase the number of contacts available on a base unit. Base units are all safety relays with feedback loop monitoring.
- ▶ Pulse relay
  - In accordance with EN ISO 12100-1 and EN ISO 12100-2 (inching circuit for limited movement of hazardous machine components during installation, set up and positioning)
  - in safety circuits in accordance with VDE 0113 and EN 60204-1 (e.g. on movable guards)
- ▶ Safe timer relays
  - in accordance with EN 1088 (release with delay through timer)
  - in safety circuits in accordance with VDE 0113-1 and EN 60204-1 (e.g. on movable guards)

The category that can be achieved in accordance with EN 954-1 and EN ISO 13849-1 depends on the category of the base unit. The contact expansion module may not exceed this.

- ▶ The unit can also be used without a base unit as a pulse relay or safe timer.

The unit is designed for use with

- ▶ Safety relays from the PNOZ X, PNOZsigma, PNOZelog, PNOZmulti series
- ▶ Safety gate monitors from the PST series
- ▶ Two-hand relays from the PNOZsigma, P2HZ series

### Safety features

The unit meets the following safety requirements:

- ▶ The unit monitors its own output contacts.
- ▶ The safety function remains effective in the case of a component failure.
- ▶ Earth fault in the feedback loop is detected.
- ▶ Earth fault in the input circuit: The output relays de-energise and the safety contacts open.
- ▶ The unit has an electronic fuse.

## up to PL e of EN ISO 13849-1 PNOZ s9

مبتکران صنعت برنا  
جهت سفارش با شماره زیر تماس بگیرید  
0990 4040 832 msborna.com

### Block diagram

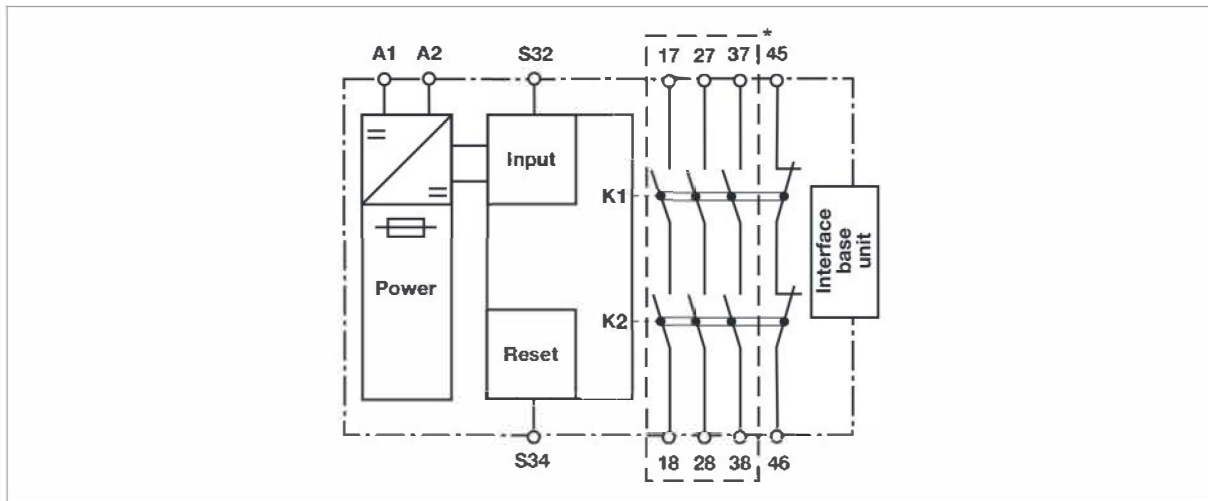

\*Safe separation in accordance with EN 60947-1, 6 kV

### Function description

- ▶ Delay-on de-energisation, not re-triggerable  
If the supply voltage at the input circuit is interrupted, the safety contacts will open once the set release time has elapsed, even if the safety function is cancelled during the delay time. The unit cannot be reactivated until the delay time has elapsed.
  - ▶ Delay-on de-energisation, retriggerable (only possible as a standalone application or with the PNOZsigma base unit!)  
If the supply voltage at the input circuit is interrupted, the safety contacts will open once the set release time has elapsed.  
If the safety function is cancelled during the delay time (e.g. safety gate closed), the unit will remain active.
  - ▶ Pulse on switching on  
The safety contacts close when supply voltage is applied, the feedback loop is closed and finally the input circuit is closed. The safety contacts are reopened once the pulse time has elapsed.  
If the input circuit is opened for more than 10 ms during the pulse time, the safety contacts will open immediately and the auxiliary contact will be closed.
  - ▶ Delay-on energisation  
The set delay time is started when supply voltage is applied, the feedback loop is closed and finally the input circuit is closed.  
If the input circuit and feedback loop are closed once the delay time has elapsed, the safety contacts will close and the auxiliary contact will be opened.  
If the input circuit is opened for more than 10 ms, the safety contacts will open immediately and the auxiliary contact will be closed.
- with PNOZsigma base unit:
- ▶ Dual-channel operation via PNOZsigma connector
- with other base units or without base unit:
- ▶ Single-channel operation: one input circuit affects the output relays

## up to PL e of EN ISO 13849-1 PNOZ s9

مبتکران صنعت برنا  
جهت سفارش با شماره زیر تماس بگیرید  
0990 4040 832 msborna.com

### Timing diagrams

#### Delay-on de-energisation, not retriggerable

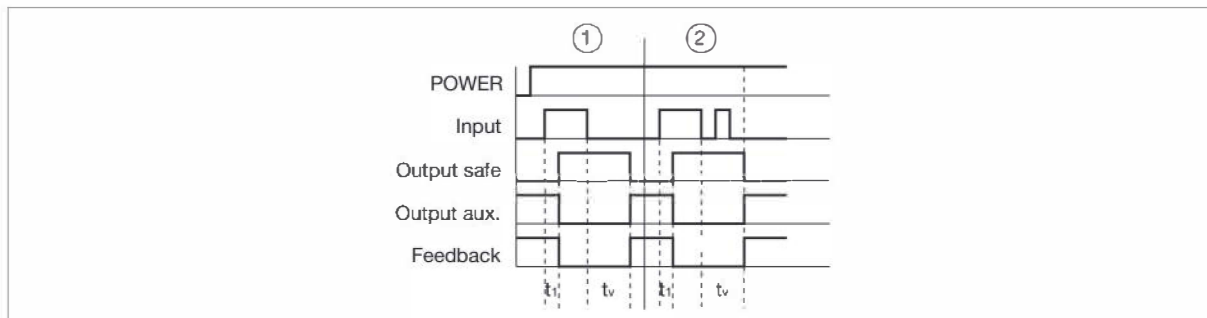

#### Key

- ▶ Power: Supply voltage
- ▶ Input: Input circuit S32
- ▶ Output safe: Safety contacts 17-18, 27-28, 37-38
- ▶ Output aux: Auxiliary contact 45-46
- ▶ Feedback: Feedback loop S34
- ▶  $t_1$ : Switch-on delay
- ▶  $t_v$ : Delay time
- ▶ ①: Delay-on de-energisation with the time  $t_v$
- ▶ ②: No retriggering in the time  $t_v$

#### Delay-on de-energisation, retriggerable

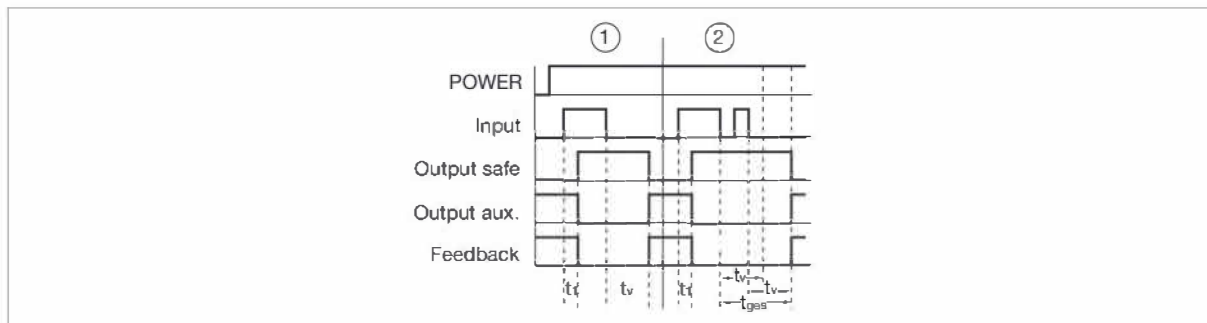

#### Key

- ▶ Power: Supply voltage
- ▶ Input: Input circuit S32
- ▶ Output safe: Safety contacts 17-18, 27-28, 37-38
- ▶ Output aux: Auxiliary contact 45-46
- ▶ Feedback: Feedback loop S34
- ▶  $t_1$ : Switch-on delay
- ▶  $t_v$ : Delay-on de-energisation
- ▶  $t_{ges}$ : Overall delay time
- ▶ ①: Delay-on de-energisation with the time  $t_v$
- ▶ ②: Retriggering in the time  $t_v$  for overall delay-on de-energisation  $t_{ges}$

## up to PL e of EN ISO 13849-1 PNOZ s9

مبتکران صنعت برنا  
جهت سفارش با شماره زیر تماس بگیرید  
0990 4040 832 msborna.com

### Pulse on switching on

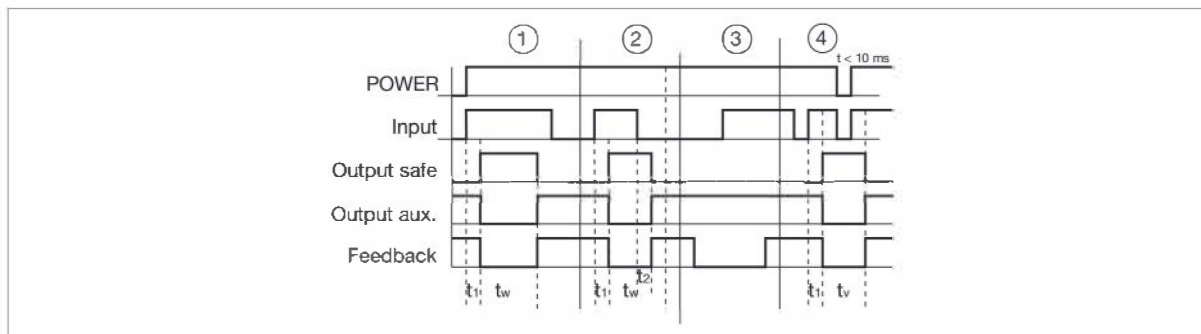

#### Key

- ▶ Power: Supply voltage
- ▶ Input: Input circuit S32
- ▶ Output safe: Safety contacts 17-18, 27-28, 37-38
- ▶ Output aux.: Auxiliary contact 45-46
- ▶ Feedback: Feedback loop S34
- ▶  $t_1$ : Switch-on delay
- ▶  $t_2$ : Delay-on de-energisation
- ▶  $t_w$ : Pulse time
- ▶ ①: Normal operating cycle
- ▶ ②: Fault: Input circuit opened too early
- ▶ ③: Fault: Feedback loop closed too late
- ▶ ④: Normal operating cycle with supply interruption < 10 ms

### Delay-on energisation

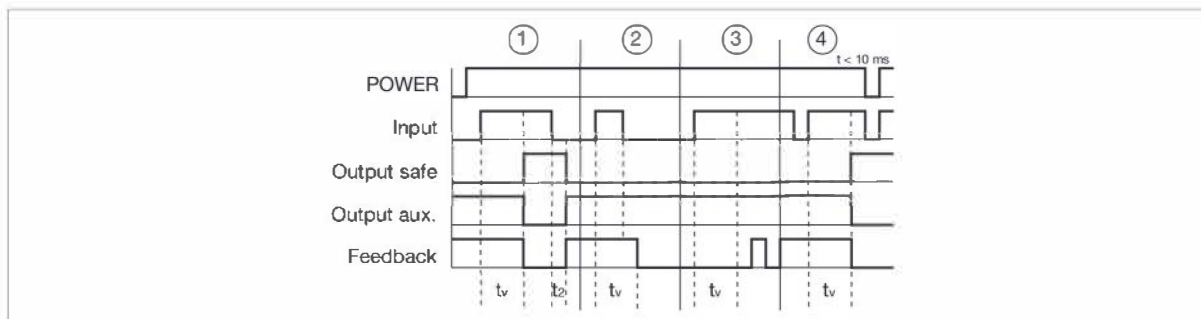

#### Key

- ▶ Power: Supply voltage
- ▶ Input: Input circuit S32
- ▶ Output safe: Safety contacts 17-18, 27-28, 37-38
- ▶ Output aux.: Auxiliary contact 45-46
- ▶ Feedback: Feedback loop S34
- ▶  $t_2$ : Delay-on de-energisation
- ▶  $t_v$ : Delay time
- ▶ ①: Normal operating cycle
- ▶ ②: Fault: Input circuit opened too early
- ▶ ③: Fault: Feedback loop closed too late after  $t_2$  elapsed
- ▶ ④: Normal operating cycle with supply interruption < 10 ms

### Wiring

#### Please note:

- ▶ Information given in the "Technical details" must be followed.
- ▶ Outputs 17-18, 27-28, 37-38 are safety contacts, output 45-46 is an auxiliary contact (e.g. for display).
- ▶ To prevent contact welding, a fuse should be connected before the output contacts (see technical details).
- ▶ Calculation of the max. cable runs  $l_{max}$  in the input circuit:
 
$$l_{max} = \frac{R_{lmax}}{R_f / km}$$

$$R_{lmax} = \text{max. overall cable resistance (see technical details)}$$

$$R_f / km = \text{cable resistance/km}$$
- ▶ Use copper wire that can withstand 60/75 °C.
- ▶ Sufficient fuse protection must be provided on all output contacts with capacitive and inductive loads.

## up to PL e of EN ISO 13849-1 PNOZ s9

مبتکران صنعت برنا  
جهت سفارش با شماره زیر تماس بگیرید  
0990 4040 832 msborna.com

### Preparing for operation

#### ► Supply voltage

| Supply voltage | AC | DC |
|----------------|----|----|
|                |    |    |

#### ► 1-channel input circuit/feedback loop

| Input circuit   | Input circuit | Feedback circuit |
|---|---------------|------------------|
| Without base unit (standalone)  |               |                  |
| Base unit:<br>Safety relay PNOZ X   |               |                  |
| Base unit:<br>Safety relay PNOZelog; driven via semi-conductor outputs (24 VDC) |               |                  |

The inputs that evaluate the feedback loop will depend on the base unit and application.

\* PNOZ e1p only; all other PNOZelog safety relays without delay-on de-energisation with PNOZ s9

## up to PL e of EN ISO 13849-1 PNOZ s9

مبتکران صنعت برنا  
جهت سفارش با شماره زیر تماس بگیرید  
0990 4040 832 msborna.com

### ► 2-channel input circuit

|   |   |   |
|---|---|---|
|   | Base unit: Safety relays<br>PNOZ s3, PNOZ s4, PNOZ s5 | Base unit: Safety relays<br>PNOZ s1, PNOZ s2  |
| The input circuit is connected and evaluated via the connector. |   |   |
|   | Base unit: Two-hand control unit<br>PNOZ s6           | Base unit: Two-hand control unit<br>PNOZ s6.1 |
| The input circuit is connected and evaluated via the connector. |   |   |

### ► Application

|                   |                       |                    |
|-------------------|-----------------------|--------------------|
|                   | without feedback loop | with feedback loop |
| without base unit |                       |                    |

### ► Key

|    |              |
|----|--------------|
| S3 | Reset button |
|----|--------------|

**up to PL e of EN ISO 13849-1**  
**PNOZ s9**

مبتکران صنعت برنا  
 جهت سفارش با شماره زیر تماس بگیرید  
 0990 4040 832 msborna.com

## Terminal configuration

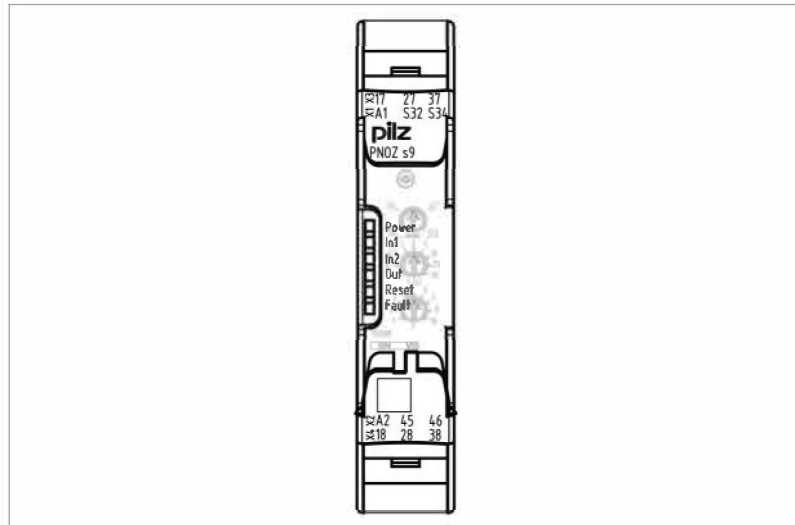

## Installation

### Install contact expander module without base unit:

- ▶ Ensure that the plug terminator is inserted at the side of the unit.

### Connect base unit and PNOZsigma contact expander module:

- ▶ Remove the plug terminator at the side of the base unit and at the contact expander module
- ▶ Connect the base unit and the contact expander module to the supplied connector before mounting the units to the DIN rail.

### Installation in control cabinet

- ▶ The safety relay should be installed in a control cabinet with a protection type of at least IP54.
- ▶ Use the notch on the rear of the unit to attach it to a DIN rail (35 mm).
- ▶ When installed vertically: Secure the unit by using a fixing element (e.g. retaining bracket or end angle).
- ▶ Push the unit upwards or downwards before lifting it from the DIN rail.

## Dimensions

\*with spring-loaded terminals

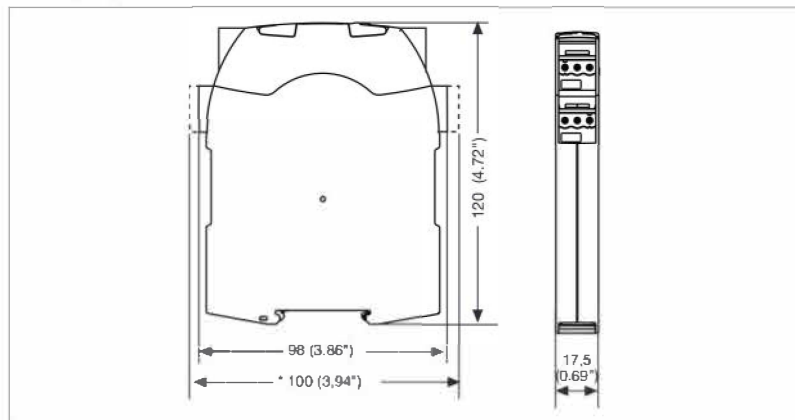

## up to PL e of EN ISO 13849-1 PNOZ s9

مبتکران صنعت برنا  
جهت سفارش با شماره زیر تماس بگیرید  
0990 4040 832 msborna.com

### NOTICE

This data sheet is only intended for use during configuration. For installation and operation, please refer to the operating instructions supplied with the unit.

### Service life graph

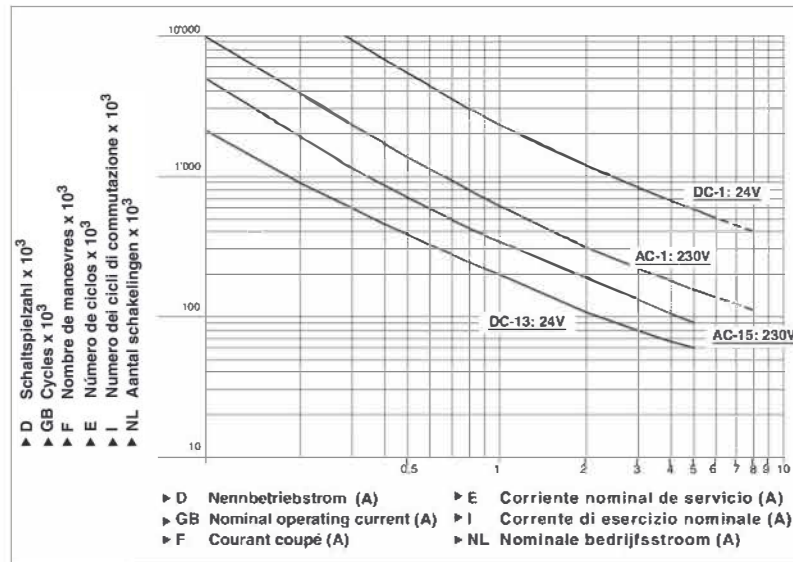

### Technical details

#### Electrical data

|   |   |
|---|---|
| Supply voltage  |   |
| Supply voltage $U_B$ DC                                     | <b>24 V</b>   |
| Voltage tolerance   | <b>-20 %/+20 %</b>                                      |
| Power consumption at $U_B$ DC                               | <b>2.0 W</b>  |
| Residual ripple DC  | <b>20 %</b>   |
| Typ. supply current at A1                                   | <b>70 mA</b>  |
| Voltage and current at                                      |   |
| Input circuit DC:   | <b>15.0 mA</b>  |
| Feedback loop DC: <b>24.0 V</b>                             | <b>15.0 mA</b>  |
| Max. inrush current impulse                                 |   |
| A1  | <b>0.70 A</b>   |
| Input circuit   | <b>0.10 A</b>   |
| Feedback loop   | <b>0.10 A</b>   |
| Number of output contacts                                   |   |
| Safety contacts (N/O), delayed:                             | <b>3</b>  |
| Auxiliary contacts (N/C), delayed:                          | <b>1</b>  |
| Utilisation category in accordance with <b>EN 60947-4-1</b> |   |
| Safety contacts: AC1 at <b>240 V</b>                        | $I_{min}: 0.01 A, I_{max}: 6.0 A$<br>$P_{max}: 1500 VA$ |
| Safety contacts: DC1 at <b>24 V</b>                         | $I_{min}: 0.01 A, I_{max}: 6.0 A$<br>$P_{max}: 150 W$   |
| Auxiliary contacts: AC1 at <b>240 V</b>                     | $I_{min}: 0.01 A, I_{max}: 6.0 A$<br>$P_{max}: 1500 VA$ |
| Auxiliary contacts: DC1 at <b>24 V</b>                      | $I_{min}: 0.01 A, I_{max}: 6.0 A$<br>$P_{max}: 150 W$   |
| Utilisation category in accordance with <b>EN 60947-5-1</b> |   |
| Safety contacts: AC15 at <b>230 V</b>                       | $I_{max}: 5.0 A$  |
| Safety contacts: DC13 at <b>24 V</b> (6 cycles/min)         | $I_{max}: 5.0 A$  |
| Auxiliary contacts: AC15 at <b>230 V</b>                    | $I_{max}: 5.0 A$  |
| Auxiliary contacts: DC13 at <b>24 V</b> (6 cycles/min)      | $I_{max}: 5.0 A$  |
| Conventional thermal current                                | <b>6.0 A</b>  |



## up to PL e of EN ISO 13849-1 PNOZ s9

مبتکران صنعت برنا  
جهت سفارش با شماره زیر تماس بگیرید  
0990 4040 832 msborna.com

| <b>Electrical data</b>  |   |
|---|---|
| Contact material  | AgCuNi + 0.2 µm Au  |
| External contact fuse protection ( $I_K = 1$ kA) to EN 60947-5-1  |   |
| Blow-out fuse, quick  |   |
| Safety contacts:  | 10 A  |
| Auxiliary contacts:   | 10 A  |
| Blow-out fuse, slow   |   |
| Safety contacts:  | 6 A   |
| Auxiliary contacts:   | 6 A   |
| Circuit breaker 24 VAC/DC, characteristic B/C                     |   |
| Safety contacts:  | 6 A   |
| Auxiliary contacts:   | 6 A   |
| Max. overall cable resistance $R_{lmax}$                          |   |
| A1/A2   | 20 Ohm  |
| Input circuit   | 30 Ohm  |
| Feedback loop   | 30 Ohm  |
| <b>Safety-related characteristic data</b>                         |   |
| PL in accordance with EN ISO 13849-1                              | PL e (Cat. 4)   |
| Category in accordance with EN 954-1                              | Cat. 4  |
| SIL CL in accordance with EN IEC 62061                            | SIL CL 3  |
| PFH in accordance with EN IEC 62061                               | 2.34E-09  |
| SIL in accordance with IEC 61511                                  | SIL 3   |
| PFD in accordance with IEC 61511                                  | 2.75E-05  |
| $t_M$ in years  | 20  |
| <b>Times</b>  |   |
| Switch-on delay   |   |
| with manual reset typ.  | 60 ms   |
| with manual reset max.  | 80 ms   |
| Delay-on de-energisation  |   |
| with E-STOP typ.  | 40 ms   |
| with E-STOP max.  | 50 ms   |
| Recovery time at max. switching frequency 1/s after power failure |   |
|   | 800 ms  |
| Delay time $t_V$ : selectable                                     |   |
|   | 0,00 s; 0,10 s; 0,20 s; 0,30 s; 0,40 s; 0,50 s; 0,60 s; 0,70 s; 0,80 s; 1,00 s; 1,50 s; 2,00 s; 2,50 s; 3,00 s; 3,50 s; 4,00 s; 5,00 s; 6,00 s; 7,00 s; 8,00 s; 10,00 s; 12,00 s; 14,00 s; 15,00 s; 16,00 s; 20,00 s; 25,00 s; 30,00 s; 35,00 s; 40,00 s; 50,00 s; 60,00 s; 70,00 s; 80,00 s; 90,00 s; 100,00 s; 120,00 s; 140,00 s; 150,00 s; 160,00 s; 180,00 s; 200,00 s; 210,00 s; 240,00 s; 300,00 s |
| Repetition accuracy   | +/- 1% + +/-20ms  |
| Repetition accuracy in the case of a fault                        | +/- 15% + +/-20ms   |
| Time accuracy   | +/- 1% + +/-20ms  |
| Supply interruption before de-energisation                        | 10 ms   |
| Supply interruption before de-energisation in the input circuit   | 10,0 ms   |
| <b>Environmental data</b>   |   |
| EMC   | EN 60947-5-1, EN 61000-6-2, EN 61000-6-4  |
| Vibration to EN 60068-2-6   |   |
| Frequency   | 10 - 55 Hz  |
| Amplitude   | 0.35 mm   |
| Climatic suitability  | EN 60068-2-78   |
| Airgap creepage in accordance with EN 60947-1                     |   |
| Pollution degree  | 2   |
| Overvoltage category  | III   |
| Rated insulation voltage  | 250 V   |
| Rated impulse withstand voltage                                   | 6.00 kV   |
| Ambient temperature   | -15 - 55 °C   |
| Storage temperature   | -40 - 85 °C   |

## up to PL e of EN ISO 13849-1 PNOZ s9

مبتکران صنعت برنا  
جهت سفارش با شماره زیر تماس بگیرید  
0990 4040 832 msborna.com

| Environmental data  |  |
|---|--|
| Protection type   |  |
| Mounting (e.g. cabinet)   | IP54   |
| Housing   | IP40   |
| Terminals   | IP 20  |
| Mechanical data   |  |
| Housing material  |  |
| Housing   | PC   |
| Front   | PC   |
| Cross section of external conductors with screw terminals   |  |
| 1 core flexible   | 0.25 - 2.50 mm <sup>2</sup> , 24 - 12 AWG No. 750109         |
| 2 core, same cross section, flexible:   |  |
| with crimp connectors, without insulating sleeve  | 0.25 - 1.00 mm <sup>2</sup> , 24 - 16 AWG No. 750109         |
| without crimp connectors or with TWIN crimp connectors  | 0.20 - 1.50 mm <sup>2</sup> , 24 - 16 AWG No. 750109         |
| Torque setting with screw terminals   | 0.50 Nm No. 750109   |
| Cross section of external conductors with spring-loaded terminals: Flexible with/without crimp connectors |  |
|   | 0.20 - 2.50 mm <sup>2</sup> , 24 - 12 AWG No. 751109, 751189 |
| Spring-loaded terminals: Terminal points per connection   | 2 No. 751109, 751189   |
| Stripping length  | 9 mm No. 751109, 751189                                      |
| Dimensions  |  |
| Height  | 100.0 mm No. 751109, 751189<br>96.0 mm No. 750109            |
| Width   | 17.5 mm  |
| Depth   | 120.0 mm   |
| Weight  | 175 g  |

No. stands for order number.

The standards current on **2007-02** apply.

| Order reference               |          |                              |           |
|-------------------------------|----------|------------------------------|-----------|
| Type                          | Features | Terminals                    | Order no. |
| PNOZ s9                       | 24 VDC   | With screw terminals         | 750 109   |
| PNOZ s9 C                     | 24 VDC   | With spring-loaded terminals | 751 109   |
| PNOZ s9 C<br>(coated version) | 24 VDC   | With spring-loaded terminals | 751 189   |