

up to PL c of EN ISO 13849-1 PNOZ s8

مبتکران صنعت برنا
جهت سفارش با شماره زیر تماس بگیرید
0990 4040 832 msborna.com



Contact expansion module for increasing the number of available contacts

Unit features

- ▶ Relay outputs:
 - 2 safety contacts (N/O), instantaneous
- ▶ 1 semiconductor output
- ▶ LED indicator for:
 - Input status, channel 1
 - Input status, channel 2
 - Switch status of the safety contacts
 - Error
- ▶ Plug-in connection terminals (either spring-loaded terminal or screw terminal)

Safety features

The unit meets the following safety requirements:

- ▶ The unit monitors its own output contacts.
- ▶ The safety function remains effective in the case of a component failure.
- ▶ Earth fault in the feedback loop: Detected, depending on the base unit that is used.
- ▶ Earth fault in the input circuit: The output relays de-energise and the safety contacts open.

Approvals

	PNOZ s8
	◆
	◆
	◆

Unit description

The unit meets the requirements of EN 60947-5-1, EN 60204-1 and VDE 0113-1. The contact expansion module is used to increase the number of instantaneous safety contacts available on a base unit. Base units are all safety relays with feedback loop monitoring.

The category that can be achieved in accordance with EN 954-1 and EN ISO 13849-1 depends on the category of the base unit. The contact expansion module may not exceed this.

Block diagram

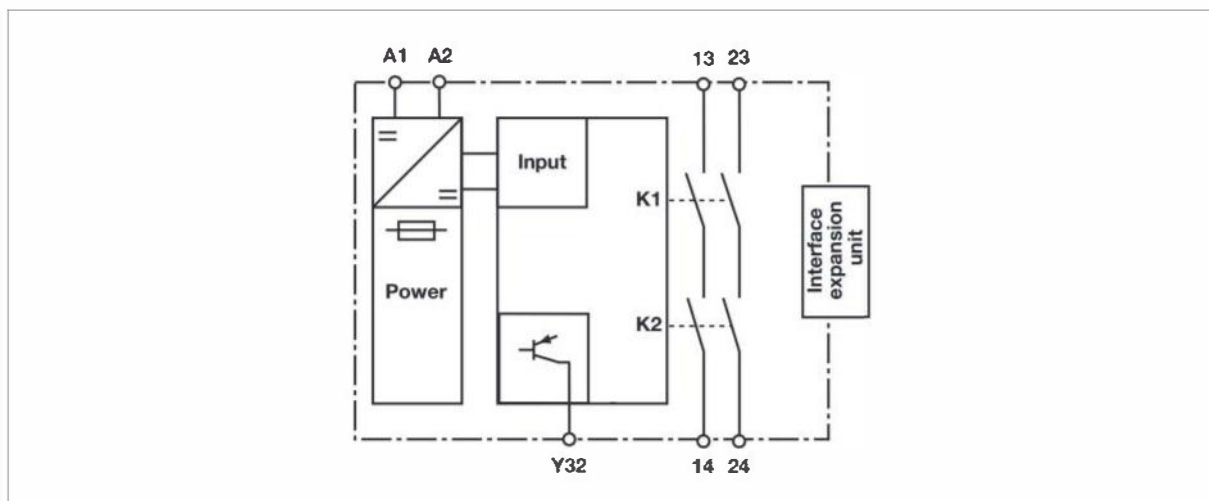

up to PL c of EN ISO 13849-1 PNOZ s8

مبتکران صنعت برنا
جهت سفارش با شماره زیر تماس بگیرید
0990 4040 832 msborna.com

Function description

with PNOZsigma base unit:
 ▶ Dual-channel operation via PNOZsigma connector

without PNOZsigma base unit:
 ▶ Single-channel operation: one input circuit affects the output relays

Timing diagram

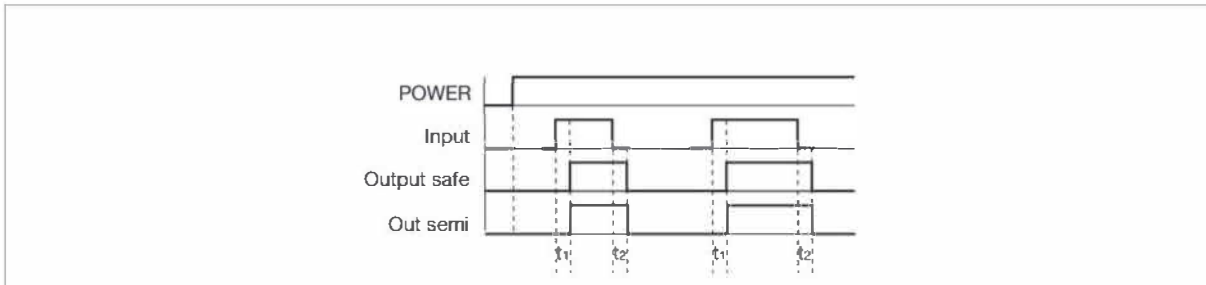

Key

- ▶ Power: Supply voltage
- ▶ Input: Input circuits A1
- ▶ Output safe: Safety contacts 13-14, 23-24
- ▶ Out semi: Semiconductor output Y32
- ▶ t_1 : Switch-on delay
- ▶ t_2 : Delay-on de-energisation

Wiring

Please note:

- ▶ Information given in the "Technical details" must be followed.
- ▶ Outputs 13-14, 23-24 are safety contacts.
- ▶ To prevent contact welding, a fuse should be connected before the output contacts (see technical details).
- ▶ Calculation of the max. cable runs l_{max} in the input circuit:

$$l_{max} = \frac{R_{lmax}}{R_l / km}$$

R_{lmax} = max. overall cable resistance (see technical details)

R_l / km = cable resistance/km

- ▶ Use copper wire that can withstand 60/75 °C.
- ▶ Sufficient fuse protection must be provided on all output contacts with capacitive and inductive loads.

up to PL c of EN ISO 13849-1 PNOZ s8

مبتکران صنعت برنا
جهت سفارش با شماره زیر تماس بگیرید
0990 4040 832 msborna.com

Preparing for operation

► Supply voltage

Supply voltage	AC	DC

► Input circuit

Input circuit	Single-channel	Dual-channel
Base unit: PNOZ X safety relay		
Base unit: PNOZelog safety relay Driven via semiconductor outputs (24 VDC)		

► Feedback loop

with PNOZsigma base unit:
The feedback loop is connected and evaluated via the connector.

without PNOZsigma base unit:
Feedback loop does not need to be monitored because the contact ex-

pansion block monitors its own output contacts.

► Semiconductor output

*Connect together the 0V connections on all the external power supplies

INFORMATION

If a base unit and a contact expander module from the PNOZsigma range are connected via the connector, no additional wiring is necessary. Do not connect A1 to the contact expander module!

up to PL c of EN ISO 13849-1 PNOZ s8

مبتکران صنعت برنا
جهت سفارش با شماره زیر تماس بگیرید
0990 4040 832 msborna.com

Terminal configuration

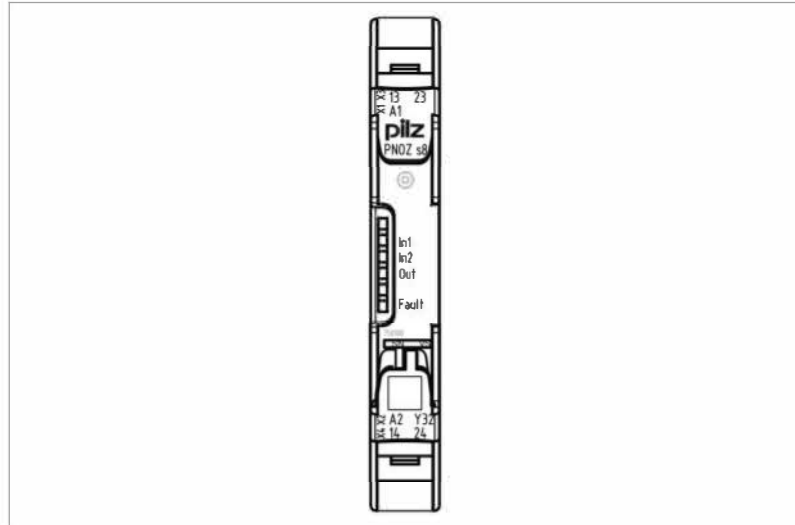

Installation

Install contact expander module without base unit:

- ▶ Ensure that the plug terminator is inserted at the side of the unit.

Connect base unit and PNOZsigma contact expander module:

- ▶ Remove the plug terminator at the side of the base unit and at the contact expander module
- ▶ Connect the base unit and the contact expander module to the supplied connector before mounting the units to the DIN rail.

Installation in control cabinet

- ▶ The safety relay should be installed in a control cabinet with a protection type of at least IP54.
- ▶ Use the notch on the rear of the unit to attach it to a DIN rail (35 mm).
- ▶ When installed vertically: Secure the unit by using a fixing element (e.g. retaining bracket or end angle).
- ▶ Push the unit upwards or downwards before lifting it from the DIN rail.

Dimensions

*with spring-loaded terminals

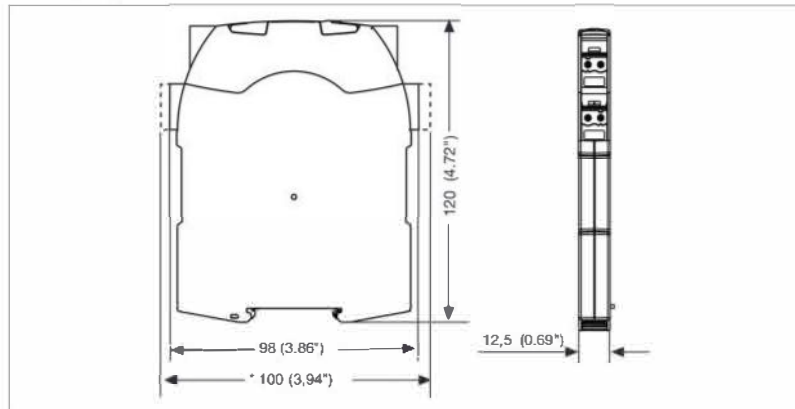

up to PL c of EN ISO 13849-1 PNOZ s8

مبتکران صنعت برنا
جهت سفارش با شماره زیر تماس بگیرید
0990 4040 832 msborna.com

NOTICE

This data sheet is only intended for use during configuration. For installation and operation, please refer to the operating instructions supplied with the unit.

Technical details	
Electrical data	
Supply voltage	
Supply voltage U_B DC	24 V
Voltage tolerance	-20 %/+20 %
Power consumption at U_B DC	2.0 W
Residual ripple DC	20 %
Voltage and current at Input circuit DC: 24.0 V	65.0 mA
Number of output contacts	
Safety contacts (S) instantaneous:	2
Utilisation category in accordance with EN 60947-4-1 Safety contacts: AC1 at 240 V	$I_{min}: 0.02 \text{ A}, I_{max}: 3.0 \text{ A}$ $P_{max}: 720 \text{ VA}$
Safety contacts: DC1 at 24 V	$I_{min}: 0.02 \text{ A}, I_{max}: 3.0 \text{ A}$ $P_{max}: 72 \text{ W}$
Utilisation category in accordance with EN 60947-5-1 Safety contacts: AC15 at 230 V	$I_{max}: 1.5 \text{ A}$
Safety contacts: DC13 at 24 V (6 cycles/min)	$I_{max}: 1.5 \text{ A}$
Contact material	AgSnO2
External contact fuse protection ($I_K = 1 \text{ kA}$) to EN 60947-5-1	
Blow-out fuse, quick	
Safety contacts:	4 A
Blow-out fuse, slow	
Safety contacts:	2 A
Circuit breaker 24 VAC/DC, characteristic B/C	
Safety contacts:	2 A
Semiconductor outputs (short circuit proof)	24.0 V DC, 20 mA
Max. overall cable resistance R_{lmax} input circuits, reset circuits single-channel at U_B DC	30 Ohm
Safety-related characteristic data	
PL in accordance with EN ISO 13849-1	PL c (Cat. 3)
Category in accordance with EN 954-1	Cat. 3
SIL CL in accordance with EN IEC 62061	SIL CL 2
PFH in accordance with EN IEC 62061	2.00E-07
SIL in accordance with IEC 61511	SIL 2
PFD in accordance with IEC 61511	6.35E-03
t_M in years	20
Times	
Switch-on delay	
with automatic reset after power on typ.	100 ms
with automatic reset after power on max.	150 ms
Delay-on de-energisation	
with E-STOP typ.	30 ms
with E-STOP max.	40 ms
with power failure typ.	30 ms
with power failure max.	40 ms

up to PL c of EN ISO 13849-1 PNOZ s8

مبتکران صنعت برنا
جهت سفارش با شماره زیر تماس بگیرید
0990 4040 832 msborna.com

Environmental data	
EMC	EN 60947-5-1, EN 61000-6-2, EN 61000-6-4
Vibration to EN 60068-2-6	
Frequency	10 - 55 Hz
Amplitude	0.35 mm
Climatic suitability	EN 60068-2-78
Airgap creepage in accordance with EN 60947-1	
Pollution degree	2
Overvoltage category	III
Rated insulation voltage	250 V
Rated impulse withstand voltage	4.00 kV
Ambient temperature	-10 - 55 °C
Storage temperature	-40 - 85 °C
Protection type	
Mounting (e.g. cabinet)	IP54
Housing	IP40
Terminals	IP20
Mechanical data	
Housing material	
Housing	PC
Front	PC
Cross section of external conductors with screw terminals	
1 core flexible	0.25 - 2.50 mm ² , 24 - 12 AWG No. 750108
2 core, same cross section, flexible:	
with crimp connectors, without insulating sleeve	0.25 - 1.00 mm ² , 24 - 16 AWG No. 750108
without crimp connectors or with TWIN crimp connectors	0.20 - 1.50 mm ² , 24 - 16 AWG No. 750108
Torque setting with screw terminals	0.50 Nm No. 750108
Cross section of external conductors with spring-loaded terminals: Flexible with/without crimp connectors	0.20 - 2.50 mm ² , 24 - 12 AWG No. 751108
Spring-loaded terminals: Terminal points per connection	2 No. 751108
Stripping length	9 mm No. 751108
Dimensions	
Height	102.0 mm No. 751108 98.0 mm No. 750108
Width	12.5 mm
Depth	120.0 mm
Weight	105 g

No. stands for order number.

All the units used within a safety function must be considered when calculating the safety characteristic data.

The standards current on 2006-04 apply.

Conventional thermal current	
I_{th} (A) at U_B DC	
1 contact	3.00 A
2 contacts	3.00 A

Order reference			
Type	Features	Terminals	Order no.
PNOZ s8	24 VDC	With screw terminal	750 108
PNOZ s8 C	24 VDC	With spring-loaded terminal	751 108