

Expansion modules PNOZ mo1p

مبتکران صنعت برنا
جهت سفارش با شماره زیر تماس بگیرید
0990 4040 832 msborna.com



Expansion module for connection to a base unit from the PNOZmulti modular safety system

Approvals

	PNOZ mo1p
	◆
	◆
	◆

Unit features

- ▶ Can be configured in the PNOZmulti Configurator
- ▶ Semiconductor outputs:
 - 2 safety outputs in accordance with EN 954-1, Cat. 4
 - or 4 safety outputs in accordance with EN 954-1, Cat. 3
- ▶ Status indicators
- ▶ Plug-in connection terminals (either cage clamp terminal or screw terminal)
- ▶ Max. 6 PNOZ mo1p units can be connected to the base unit

Unit description

The expansion module may only be connected to a base unit from the PNOZmulti modular safety system. The PNOZmulti modular safety system is used for the safety-related interruption of safety circuits and is designed for use in:

- ▶ Emergency stop equipment
- ▶ Safety circuits in accordance with VDE 0113 Part 1 and EN 60204-1

Safety features

The relay conforms to the following safety criteria:

- ▶ The circuit is redundant with built-in self-monitoring.
- ▶ The safety function remains effective in the case of a component failure.
- ▶ The safety outputs are tested periodically using a disconnection test.

Block diagram

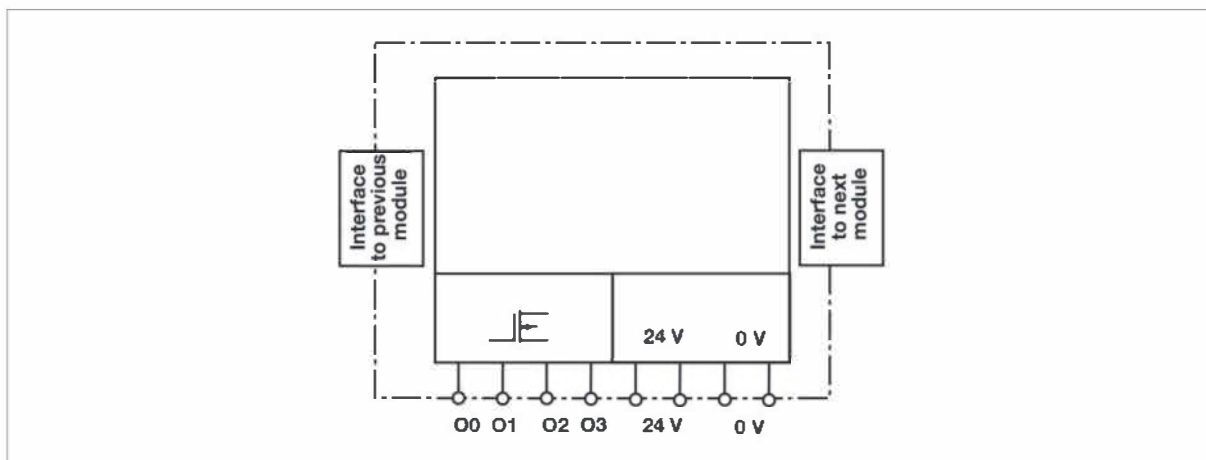

Expansion modules PNOZ mo1p

مبتکران صنعت برنا
جهت سفارش با شماره زیر تماس بگیرید
0990 4040 832 msborna.com

Function description

The expansion module provides additional semiconductor outputs.

The function of the outputs on the safety system depends on the safety circuit created using the PNOZmulti

Configurator. A chip card is used to download the safety circuit to the base unit. The base unit has 2 microcontrollers that monitor each other. They evaluate the input circuits on the base unit and expansion modules and

switch the outputs on the base unit and expansion modules accordingly. The online help on the PNOZmulti Configurator contains descriptions of the operating modes and all the functions of the PNOZmulti safety system, plus connection examples.

Wiring

The wiring is defined in the circuit diagram in the Configurator.

Please note:

- ▶ Information given in the "Technical details" must be followed.
- ▶ Outputs O0 to O3 are semiconductor outputs.
- ▶ Use copper wire that can withstand 75 °C.

Expansion modules PNOZ mo1p

مبتکران صنعت برنا
جهت سفارش با شماره زیر تماس بگیرید
0990 4040 832 msborna.com

Preparing for operation

► Supply voltage

Supply voltage	AC	DC

► Semiconductor outputs

Redundant output		
Single output		

► Feedback loop

Feedback loop	Redundant output	
Contacts from external contactors		

Expansion modules PNOZ mo1p

مبتکران صنعت برنا
جهت سفارش با شماره زیر تماس بگیرید
0990 4040 832 msborna.com

Terminal configuration

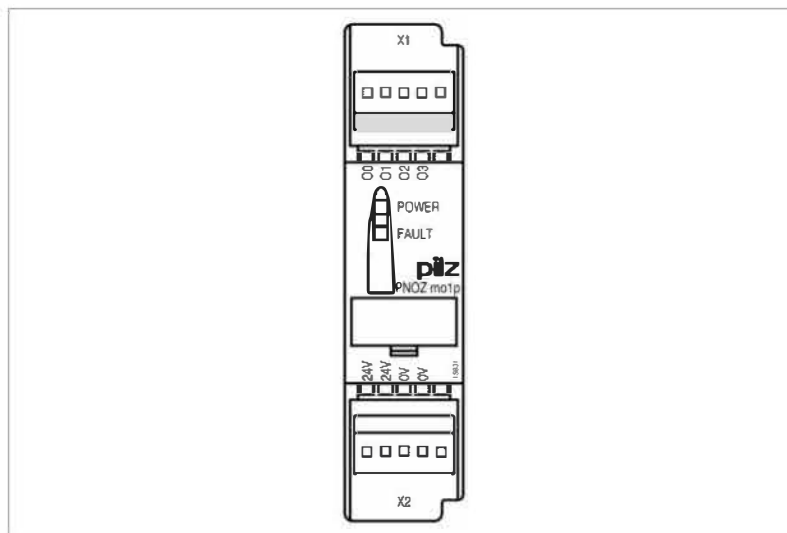

Installation

- ▶ The safety system should be installed in a control cabinet with a protection type of at least IP54. Fit the safety system to a horizontal DIN rail. The venting slots must face upward and downward. Other mounting positions could damage the safety system.
- ▶ Use the notches on the back of the unit to attach it to a DIN rail. Connect the safety system to the DIN rail in an upright position, so that the earthing springs on the safety system are pressed on to the DIN rail.
- ▶ To comply with EMC requirements, the DIN rail must have a low impedance connection to the control cabinet housing.

Dimensions

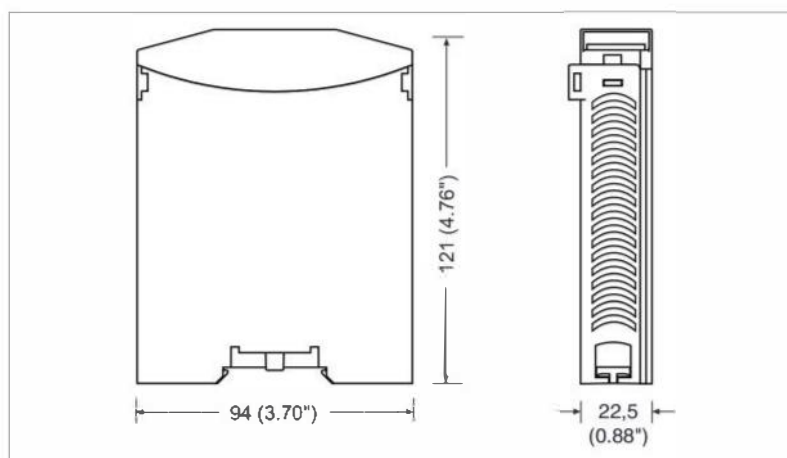

Expansion modules PNOZ mo1p

مبتکران صنعت برنا
جهت سفارش با شماره زیر تماس بگیرید
0990 4040 832 msborna.com

**Maximum capacitive load C (μF)
with load current I (mA) at the semi-
conductor outputs**

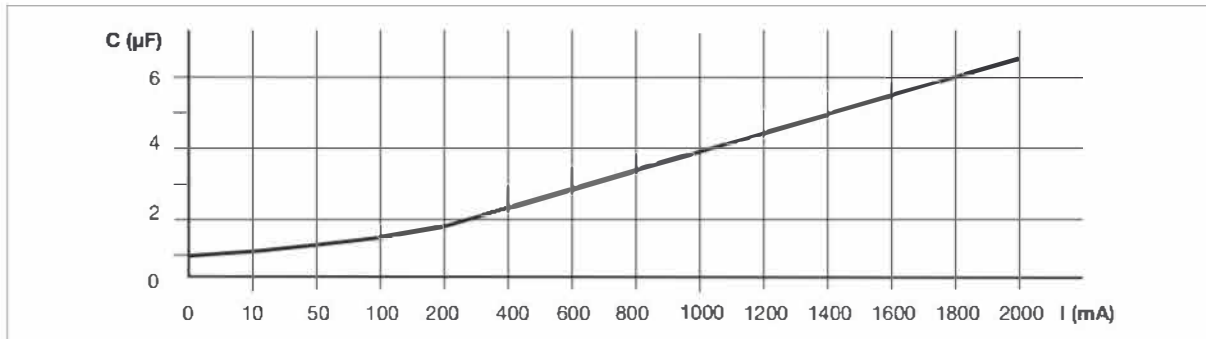

Notice

This data sheet is only intended for use during configuration. For installation and operation, please refer to the operating instructions supplied with the unit.

Technical details

Electrical data

Supply voltage (U_B) via base unit	24 VDC
Voltage tolerance	-15% ... 10%
Power consumption at U_B without load	< 2.5 W
Residual ripple U_B	+/- 5%

Times

Switch-on delay	5 s (after U_B is applied)
Supply interruption before de-energisation	Min. 20 ms

Semiconductor outputs

Number	2
for EN 954-1, 12/96, Cat. 4	4
for EN 954-1, 12/96, Cat. 3	
Switching capability	24 VDC / max. 2 A / max. 48 W
Max. capacitive load	See diagram
External supply voltage (U_B)	24 VDC
Voltage tolerance	-15% - 10%
Off time during self test	< 300 μs
Galvanic isolation	Yes
Short circuit protection	Yes
Switch-off delay	< 30 ms
Residual current at "0"	< 0.5 mA
Signal level at "1"	U_B - 0.5 VDC at 2 A
Status indicator	LED

Environmental data

Airgap creepage	DIN VDE 0110-1, 04/97
Vibration in accordance with EN 60068-2-6, 01/00	
Frequency:	10 ... 55 Hz
Amplitude:	0.35 mm
Climatic suitability	EN 60068-2-78, 10/01
EMC	EN 60947-5-1, 11/97

Expansion modules PNOZ mo1p

مبتکران صنعت برنا
جهت سفارش با شماره زیر تماس بگیرید
0990 4040 832 msborna.com

Environmental data	
Ambient temperature	0 ... + 55 °C
Storage temperature	-25 ... + 70 °C
Mechanical data	
Protection type	
Mounting (e.g. cabinet)	IP54
Housing	IP20
Terminals	IP20
DIN rail	
Top hat rail	35 x 7.5 EN 50022
Recess width	27 mm
Cable cross section	
Rigid single-core, flexible multi-core or multi-core with crimp connector	0.5 ... 1.5 mm ²
Torque setting for connection terminals (screws)	0.2 ... 0.25 Nm
Housing material	
Housing	PPO UL 94 V0
Front	ABS UL 94 V0
Dimensions (H x W x D)	94 x 22.5 x 121 mm
Weight with connector	150 g

Order reference			
Type	Features		Order no.
PNOZ mo1p	Expansion module	2 or 4 semiconductor outputs, safe	773 500