

# Expansion modules

## PNOZ mc3p

مبتکران صنعت برنا  
جهت سفارش با شماره زیر تماس بگیرید  
0990 4040 832 msborna.com



Expansion module for connection to a base unit from the PNOZmulti modular safety system

### Approvals

PNOZ mc3p	
	◆
	◆

### Unit features

- ▶ Can be configured in the PNOZmulti Configurator
- ▶ Connection for PROFIBUS-DP
- ▶ Station addresses from 0 ... 99, selected via rotary switch
- ▶ Status indicators for communication with PROFIBUS-DP and for errors
- ▶ Max. 1 PNOZ mc3p units can be connected to the base unit
- ▶ A maximum of 24 outputs on the PNOZmulti safety system can be defined in the PNOZmulti Configurator for communication with PROFIBUS-DP. These outputs can be connected to outputs on
  - Logic elements
  - Time elements
  - Event counters
  - Connection points
  - Inputs on the safety system.

### Unit description

The expansion module may only be connected to a base unit from the PNOZmulti modular safety system. It connects the PNOZmulti modular safety system to PROFIBUS-DP. The PNOZmulti modular safety system is used for the safety-related interruption of safety circuits. The unit is designed for use in:

- ▶ Emergency stop equipment
- ▶ Safety circuits in accordance with VDE 0113 Part 1 and EN 60204-1

The PNOZ mc3p expansion module is used for communication between the PNOZmulti modular safety system and PROFIBUS-DP.

PROFIBUS-DP is designed for fast data exchange at field level. The PNOZ mc3p expansion module is a passive PROFIBUS-DP subscriber (Slave). The basic functions of communication with PROFIBUS-DP conform to EN 50170. The central controller (Master) reads input information from the slaves and writes output information to the slaves as part of each cycle. As well as the cyclical transfer of usable data, PROFIBUS-DP can also be used for diagnostics and commissioning functions. Data traffic is monitored on the Master/Slave side.

The expansion module may not be used for safety-related functions.

### System requirements

- ▶ PNOZmulti Configurator: from Version 3.0.0
  - ▶ Base unit PNOZ m1p: from Version 3.0
- Please contact Pilz if you have an older version.

### Block diagram

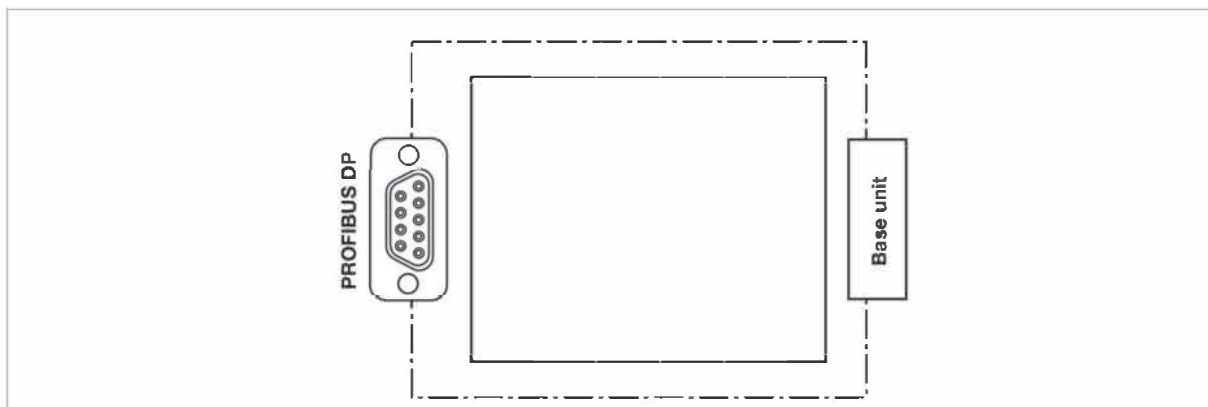

## Expansion modules PNOZ mc3p

مبتکران صنعت برنا  
جهت سفارش با شماره زیر تماس بگیرید  
0990 4040 832 msborna.com

### Function description

The data to be transferred via PROFIBUS-DP is selected and configured in the PNOZmulti Configurator. The base

unit and the PNOZ mc6p are connected via a jumper. The PNOZ mc6p is also supplied with voltage via this jumper. The station address is set via 2 rotary switches. After the supply

voltage is switched on or the PNOZmulti safety system is reset, the PNOZ mc6p is configured and started automatically.

### Wiring

The wiring is defined in the circuit diagram of the PNOZmulti Configurator. It is possible to define which outputs on the safety system will communicate with PROFIBUS-DP. The connection to PROFIBUS-DP is made via a female 9-pin D-Sub connector

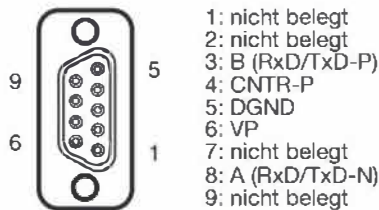

Please note:

- ▶ Information given in the "Technical details" must be followed.
- ▶ Use copper wire that can withstand 75 °C.

Please note the following when connecting to PROFIBUS-DP:

- ▶ Only use metal plugs or metallised plastic plugs
- ▶ Twisted pair, screened cable must be used to connect the interfaces

## Expansion modules PNOZ mc3p

مبتکران صنعت برنا  
جهت سفارش با شماره زیر تماس بگیرید  
0990 4040 832 msborna.com

### Terminal configuration

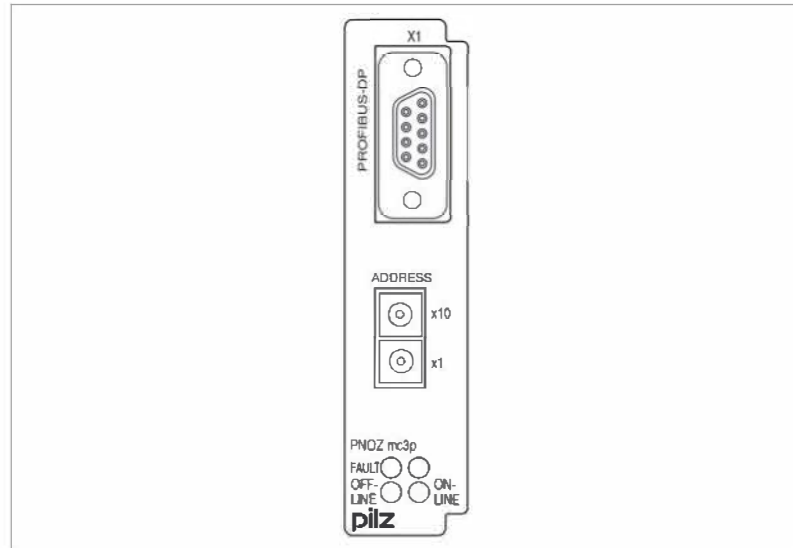

### Installation

- ▶ The safety system should be installed in a control cabinet with a protection type of at least IP54. Fit the safety system to a horizontal DIN rail. The venting slots must face upward and downward. Other mounting positions could damage the safety system.
- ▶ Use the notches on the back of the unit to attach it to a DIN rail. Connect the safety system to the DIN rail in an upright position, so that the earthing springs on the safety system are pressed on to the DIN rail.
- ▶ To comply with EMC requirements, the DIN rail must have a low impedance connection to the control cabinet housing.

The expansion module must always be installed to the left of the base unit. A distance of at least 20 mm must be maintained between the expansion module and any external heat sources.

### Dimensions

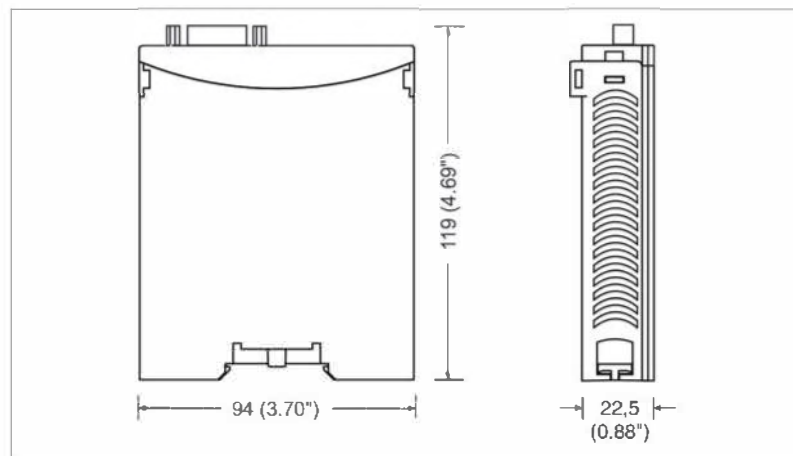

## Expansion modules PNOZ mc3p

مبتکران صنعت برنا  
جهت سفارش با شماره زیر تماس بگیرید  
0990 4040 832 msborna.com

### Notice

This data sheet is only intended for use during configuration. For installation and operation, please refer to the operating instructions supplied with the unit.

### Technical details

#### Electrical data

Supply voltage (U <sub>g</sub> ) via base unit	<b>24 VDC</b>
Power consumption at U <sub>g</sub>	<b>Max 2.5 W</b>

#### Times

Supply interruption before de-energisation	<b>Min. 20 ms</b>
--	-------------------

#### PROFIBUS-DP

Application range	<b>Non-safety-related applications</b>
Device type	<b>Slave</b>
Status indicator	<b>LED</b>
Station address	<b>0 ... 99</b>
Transmission rate	<b>9.6 kBit/s ... 12 MBit/s</b>
Connection	<b>Female 9-pin D-Sub connector</b>
Galvanic isolation	<b>Yes</b>
Test voltage	<b>500 VAC</b>

#### Environmental data

Vibration in accordance with <b>EN 60068-2-6, 04/95</b>	
Frequency:	<b>10 ... 55 Hz</b>
Amplitude:	<b>0.35 mm</b>
Climatic suitability	<b>DIN IEC 60068-2-3, 12/86</b>
EMC	<b>EN 61000-6-2, 10/01</b>
Ambient temperature	<b>0 ... + 55 °C</b>
Storage temperature	<b>-25 ... + 70 °C</b>

#### Mechanical data

Protection type	
Mounting (e.g. cabinet)	<b>IP54</b>
Housing	<b>IP20</b>
Terminals	<b>IP20</b>
DIN rail	
Top hat rail	<b>35 x 7.5 EN 50022</b>
Inner width	<b>27 mm</b>
Housing material	
Housing	<b>PPO UL 94 V0</b>
Front	<b>ABS UL 94 V0</b>
Dimensions (H x W x D)	<b>94 x 22.5 x 119 mm</b>
Weight with connector	<b>140 g</b>

### Order reference

Type	Features	Order no.
PNOZ mc3p	Expansion module	Fieldbus module, PROFIBUS-DP 773 721